



JY-6313

Specs and Manual



Specs and Manual Version: V1.1.0

1. JY-6313 Specifications

1.1 Overview



The JY-6313 is a high-density strain measurement module designed for precision applications, offering 16 channels and supporting quarter, half, and full bridge configurations. With five gain options and a 24-bit high-resolution ADC, it ensures accurate and customizable measurements. Its onboard 128M FIFO buffer allows extensive data storage, while remote sensing for bridge excitation improves accuracy. Additional features like hardware offset nulling and programmable shunt calibration eliminate errors, enhancing reliability. It supports analog, digital, and software triggers for versatile testing needs, and is compatible with both PXIe and PCIe platforms, making it a robust choice for diverse testing environments.

🔗 Please download JYTEK <[JYPEDIA](#)>, you can quickly inquire the product prices, the key features and available accessories.

1.2 Main Features

- Up to 0.21% accuracy
- Up to 80kS/s per channel simultaneous sampling.
- High-density strain measurements, providing 16 channels.
- Support quarter, half and full bridge configuration.
- 5 gain options, flexible adjustment.
- 24-bit high-resolution ADC, ensuring accurate measurement.
- Onboard 128M sample FIFO buffer, data storage is carefree.
- Bridge excitation remote sensing function, improve the measurement accuracy.
- Hardware offset nulling function allows zeroing the input without loss of dynamic range.
- Programmable shunt calibration can be used to eliminate system errors in the field.
- Analog, digital and software triggers to meet diverse testing requirements.

1.3 Hardware Specifications

1.3.1 Input Characteristics

Number of channels	16
ADC resolution	24
Type of ADC	Delta-Sigma
Sampling mode	Simultaneous
Sample rate range	7.8125 S/s ~ 80 kS/s
Sample rate resolution	$\leq 30.517 \mu\text{S/s}$
Data Transfer	DMA
FIFO buffer size	128M Samples
Linear input voltage range on AI+ and AI-	0.2 V ~ 3.6 V
CMRR (DC to 60Hz, Gain = 6.25)	76 dB

Table 1 Input Characteristics

1.3.2 Input Range

Input Gain	Ratiometric Range ($\pm\text{mV/V}$)
6.25	$400/V_{\text{ex}}$
12.5	$200/V_{\text{ex}}$
25	$100/V_{\text{ex}}$
50	$50/V_{\text{ex}}$
100	$25/V_{\text{ex}}$

Table 2 Input Range

*V_{ex}: Bridge excitation voltage.

1.3.3 Fault Protection

Powered On	30 V
Powered Off	30 V
EX +/-	Short

Table 3 Fault protection

1.3.4 Strain Bridge Specification

Bridge Completion

Modes	Full, Half, Quarter
Selection	Software selectable, per channel
Location	On terminal block TB-6313D*
Half-bridge completion	
... Offset Tolerance	$\pm 125 \mu\text{V/V}$ max
... Stability	$3.8 \mu\text{V/V}$ per °C max
Quarter-bridge completion	
... Values	120 Ω , 350 Ω , 1000 Ω . Software selectable.
... Tolerance	$\pm 0.1\%$ max
... Stability	25 ppm/°C max
... Calibration	Factory calibrated
*The bridge completion function provided by the terminal block TB-6313D. If TB-6313D is not used, JY-6313 can only connect to the full-bridge input.	

Table 4 Bridge Completion

Offset Nulling

Type	Hardware nulling
Nulling Range	
... Gain = 6.25	$\pm 200 \text{ mV}$

... Gain = 12.5	±150 mV
... Gain = 25.0	±125 mV
... Gain = 50.0	±112.5 mV
... Gain = 100	±106.25 mV

Table 5 Offset Nulling

Shunt Calibration

Selection	Software selectable, per channel
Location	On terminal block TB-6313D*
Values	50kΩ, 100kΩ. Software selectable*
Tolerance	0.1% max
Stability	25ppm/°C max
Calibration	Factory calibrated
<p>*50kΩ and 100kΩ shunt resistors are provided by terminal block TB-6313D. If TB-6313D is not used, you need to connect another shunt resistor to the shunt circuit and write the exact resistance value of the resistor to the corresponding interface of the driver.</p>	

Table 6 Shunt Calibration

Excitation Characteristics

Number of output channels	2
Selection	Software selectable, Ch0 ~ Ch7 and Ch8 ~ Ch15 share one excitation channel each
Excitation type	Constant differential voltage (balanced)
Values (Vex)	1 V ~ 10 V
Resolution	about 2.44 mV
Accuracy	0.1%
Max current	30 mA per channel
Max fault current	60 mA per channel
Excitation noise	150 μ Vrms
Short-circuit protection	EX to GND and between terminals

Table 7 Excitation Characteristics

Bridge Resistance (individual element)	Bridge Configuration	Vex(max)
120 Ω	Full	3.3V
	Half and Quarter	6V
350 Ω	Full	10V
	Half and Quarter	10V
1k Ω	Full	10V
	Half and Quarter	10V

Table 8 Excitation limit

1.3.5 Absolute Accuracy

Ratiometric Input Accuracy

Input Gain	Ratiometric Range ($V_{ex}=5V$)	Gain Error (% of Reading)	Offset Error ($\mu V/V$)
6.25	± 80 mV/V	0.09	480 / V_{ex}
12.5	± 40 mV/V	0.09	380 / V_{ex}
25	± 20 mV/V	0.09	350 / V_{ex}
50	± 10 mV/V	0.09	340 / V_{ex}
100	± 5 mV/V	0.12	340 / V_{ex}

Table 9 90-day Accuracy ($23^{\circ}C \pm 5^{\circ}C$)

* V_{ex} : Bridge excitation voltage.

1.3.6 Input Noise

Excitation Voltage	Input Noise (uVrms/V)				
	Gain=6.25	Gain=12.5	Gain=25	Gain=50	Gain=100
1 V	23	15	13	12	12
1.25 V	20	12	10	9.6	9.4
2 V	12	7.7	6.3	6.0	5.9
2.5 V	8.9	6.4	5.2	4.8	4.8
3.3 V	7.0	4.6	3.9	3.6	3.6
5 V	4.6	3.1	2.7	2.5	2.4
10	2.3	1.5	1.3	1.2	1.2

*During the test, the sample rate was 80kS/s, and 350Ω full-bridge was connected.

Table 10 Input Noise

1.3.7 Dynamic Performance

Channel-to-channel phase matching	100 ns
SFDR (1kHz, -1dBFS)	73 dB
THD (1kHz, -1dBFS)	-72 dB
Crosstalk ($f_{in} = 1\text{kHz}$, cable effects not included)	$\leq -110\text{ dBc}$

Table 11 Dynamic Performance

1.3.8 Bandwidth and Alias Rejection

Passband Frequency	
... for $7.8125\text{S/s} \leq f_s < 500\text{S/s}$	$0.1 * f_s$
... for $500\text{S/s} \leq f_s \leq 80\text{kS/s}$	$0.4535 * f_s$
Passband Flatness (80kS/S, for 1Hz - 36.28kHz in)	0.1 dB
Stopband Frequency	

... for $7.8125S/s \leq f_s < 500S/s$	$0.9 * f_s$
... for $500S/s \leq f_s \leq 80kS/s$	$0.5465 * f_s$
Stopband Rejection	
... for $500S/s \leq f_s \leq 80kS/s$	100 dB
Alias-free bandwidth	
... for $7.8125S/s \leq f_s < 500S/s$	$0.1 * f_s$
... for $500S/s \leq f_s \leq 80kS/s$	$0.4535 * f_s$

Table 12 Bandwidth and Alias Rejection (Operation Mode = Auto*)

*Operation Mode: JY-6313 digital filters offer two modes, Normal and Low-Latency, each with different support sample rate ranges, group latency and passband bandwidth, and by default, the driver automatically selects according to the sample rate. See Chapter 7.3 for a more detailed description.

1.3.9 Digital Filter Group Delay

Sample Rate	Group Delay (Samples)
$7.8125S/s \leq f_s \leq 62.5S/s$	0.82
$62.5S/s < f_s < 500S/s$	0.88
$500S/s \leq f_s \leq 32kS/s$	33.38
$32kS/s < f_s \leq 64kS/s$	41.25
$64kS/s < f_s \leq 80kS/s$	48.00

Table 13 Digital Filter Group Delay (Operation Mode = Auto)

1.3.10 Triggers

Analog Trigger

Source	All channels
Purpose	Start or reference trigger
Mode	Rising-edge, Rising-edge with hysteresis, Falling-edge, Falling-edge with hysteresis, Entering Window, Leaving Window

Table 14 Analog Trigger

Digital Trigger

Source	PFIO, PXI_TRIG<0..7>, PXI_STAR
Purpose	Start or reference trigger
Polarity	Software-selectable

Table 15 Digital Trigger

1.3.11 Internal Frequency Timebase Characteristics

Reference Clock Source	Onboard 10 MHz clock, Backplane PXIe_CLK100
10MHz Clock	
... Frequency	10 MHz
... Accuracy	±0.3 ppm

Table 16 Internal Frequency Timebase Characteristics

1.3.12 Output Timing Signals

Sources	Sample Clock, Start Trigger Out, Reference Trigger Out
Destinations	PFI0, PXI_TRIG<0..7>
Polarity	Software-selectable

Table 17 Output Timing Signals

1.3.13 Power Requirements

+12 V	1.7 A (Max)
+3.3 V	0.4 A (Max)

Table 18 Power Requirements

1.3.14 PFI Characteristics

Absolute input voltage range	-0.5 V to 4.3 V
Recommended input voltage range	0 V to 3.3 V
VIH	2.0 V
VIL	0.8 V
Input impedance	50 kΩ typical, internal pull-down resistor

Table 19 PFI Characteristics (Input)

VOH	3.1 V with IOH = 100 μ A 2.6 V with IOH = 12 mA
VOL	0.2 V with IOL = -100 μ A 0.7 V with IOL = -12 mA
Output Range	0 V to 3.3 V
Output short Current	\pm 50 mA
Output Impedance	33 Ω

Table 20 PFI Characteristics (Output)

1.3.15 Bus Interface

	PXIe-6313	PCle-6313	USB-6313
Bus Type	x4 PXI Express peripheral module Specification V1.0 compliant	x4 PCI Express 2.0	Type-C USB 3.0

Table 21 Bus Interface

1.3.16 Physical and Environment

Physical Characteristics

Dimensions	200x100x20 mm
Weight	222 g

Table 22 Physical Requirements

Environmental Specifications

Maximum altitude	2,000 m (800 mbar)
Pollution Degree	2

Table 23 Environmental Specifications

Operating Environment

Ambient temperature range	0 °C to 50 °C
Relative humidity range	10% to 90%, noncondensing

Table 24 Operating Environment

Storage Environment

Ambient temperature range	-40 °C to 71 °C
Relative humidity range	5% to 95%, noncondensing

Table 25 Storage Environment

1.3.17 Electromagnetic Compatibility

ESD:4kV Air discharge, IEC 61000-4-2

2. Order Information

- PXIe-6313 (PN: JY9210887-01)

16-ch, 80kS/s, 24-Bit, PXIe Strain/Bridge Input Module

- Accessories:

Cable:

ACL-1016868-1 1M 68pin VHDC-SCSI twisted pair cable (PN: JY7996916-01)

ACL-1016868-2 2M 68pin VHDCI-SCSI twisted pair cable (PN: JY7996916-02)

Terminal Block:

TB-6313D: 8-ch for PCIe/PXIe-6313 (PN: JY6727662-01)

Table of Contents

1.JY-6313 Specifications.....	1
1.1 Overview	1
1.2 Main Features	1
1.3 Hardware Specifications	2
1.3.1 Input Characteristics	2
1.3.2 Input Range.....	2
1.3.3 Fault Protection	2
1.3.4 Strain Bridge Specification	3
1.3.5 Absolute Accuracy	6
1.3.6 Input Noise.....	7
1.3.7 Dynamic Performance.....	7
1.3.8 Bandwidth and Alias Rejection.....	7
1.3.9 Digital Filter Group Delay	9
1.3.10 Triggers.....	9
1.3.11 Internal Frequency Timebase Characteristics	10
1.3.12 Output Timing Signals	10
1.3.13 Power Requirements.....	10
1.3.14 PFI Characteristics	10
1.3.15 Bus Interface.....	12
1.3.16 Physical and Environment	12
1.3.17 Electromagnetic Compatibility	13
2.Order Information.....	13
3.Introduction.....	21
3.1 Overview	21

3.2 Abbreviations	21
3.3 JYPEDIA and Learn by Example	21
4. Hardware Specifications	22
4.1 System Diagram	22
4.2 Front Panel	24
4.3 Pin Definition	24
4.4 Gain and Offset Errors	29
4.5 Ratiometric (mV/V) Measurement Accuracy	29
4.6 Example of Calculating Gain and Offset Errors	29
5. Software	31
5.1 System Requirements	31
5.2 System Software	31
5.3 C# Programming Language	32
5.4 JY-6313 Hardware Driver	33
5.5 Install the SeeSharpTools from JYTEK.....	33
5.6 Running C# Programs in Linux.....	33
6. Connecting Wheatstone Bridge.....	34
6.1 Wheatstone Bridge	34
6.2 Options to Correct for Resistance Errors	35
6.2.1 Remote Sensing	36
6.2.2 Offset Nulling	38
6.2.3 Shunt Calibration	38
6.3 Using Terminal Block TB-6313D	40
6.4 Using Terminal Block TB-68	43

6.5 Strain Gage Configurations	44
6.5.1 Quarter-Bridge Type I.....	45
6.5.2 Quarter-Bridge Type II.....	47
6.5.3 Half-Bridge Type I	49
6.5.4 Half-Bridge Type II	51
6.5.5 Full-Bridge Type I.....	53
6.5.6 Full-Bridge Type II.....	55
6.5.7 Full-Bridge Type III.....	57
6.6 Ratiometric Measurement Configuration	59
7.Operating JY-6313	62
7.1 Quick Start.....	62
7.2 Acquisition Methods.....	62
7.2.1 Continuous Acquisition	65
7.2.2 Finite Acquisition	65
7.2.3 Single Point	65
7.3 Operation Modes.....	65
7.3.1 Normal Mode	65
7.3.2 Low-Latency Mode	66
7.3.3 Auto Mode	67
7.4 Strain Measurement Range	67
7.5 Bridge Calibration	69
7.5.1 Perform Offset Nulling	70
7.5.2 Perform Shunt Calibration	71
7.5.3 Use Offset Nulling and Shunt Calibration Manually	71

7.6 Triger Source.....	73
7.6.1 Immediate trigger	73
7.6.2 Soft trigger	73
7.6.3 External Analog Trigger	74
7.6.4 External Digital Trigger	79
7.7 Trigger Mode	80
7.7.1 Start Trigger	80
7.7.2 Reference Trigger	81
7.7.3 Retrigger.....	82
7.8 Sync.....	83
8.Calibration	87
9.Using JY-6313 in Other Software	87
9.1 Python.....	87
10.About JYTEK.....	88
10.1 JYTEK China.....	88
10.2 JYTEK Software Platform	88
10.3 JYTEK Warranty and Support Services.....	88
11.Statement	89
Table 1 Input Characteristics	2
Table 2 Input Range.....	2
Table 3 Fault protection.....	3
Table 4 Bridge Completion	3
Table 5 Offset Nulling	4

Table 6 Shunt Calibration..... 4

Table 7 Excitation Characteristics 5

Table 8 Excitation limit 5

Table 9 90-day Accuracy (23°C±5°C) 6

Table 10 Input Noise..... 7

Table 11 Dynamic Performance..... 7

Table 12 Bandwidth and Alias Rejection (Operation Mode = Auto*)..... 8

Table 13 Digital Filter Group Delay (Operation Mode = Auto)..... 9

Table 14 Analog Trigger 9

Table 15 Digital Trigger 9

Table 16 Internal Frequency Timebase Characteristics 10

Table 17 Output Timing Signals..... 10

Table 18 Power Requirements 10

Table 19 PFI Characteristics (Input) 10

Table 20 PFI Characteristics (Output)..... 11

Table 21 Bus Interface 12

Table 22 Physical Requirements 12

Table 23 Environmental Specifications 12

Table 24 Operating Environment..... 12

Table 25 Storage Environment 12

Table 26 Front Panel Pinout Description 25

Table 27 Front Panel Pinout Definition 26

Table 28 TB-6313D DB15 Pinout Definition..... 28

Table 29 Calculating Gain and Offset Errors 30

Table 30 Supported Linux Versions.....	31
Table 31 TB-6313D DB15 Pinout Definition.....	42
Table 32 Front Panel Pin Definition	44
Table 33 Digital Filter Group Delay (Operation Mode = Normal).....	65
Table 34 Digital Filter Group Delay (Operation Mode = LowLatency)	66
Table 35 Mircostrain range in different configurations	69
Figure 1 Full-Bridge Input and TB-6313D/JY-6313	23
Figure 2 JY-6313 Front Panel	24
Figure 5 Wheatstone Bridge	35
Figure 6 Ideal and Actual Load Response on the Bridge	36
Figure 7 Voltage Drop Due to Lead Resistance	37
Figure 8 Connecting Remote Sensing to JY-6313	37
Figure 9 Hardware Offset Nulling Process.....	38
Figure 10 Shunt Calibration Diagram	39
Figure 11 TB-6313D	40
Figure 12 The front of TB-6313D	41
Figure 13 The back of TB-6313D.....	42
Figure 14 Connecting via TB-6313D.....	42
Figure 15 TB-68	43
Figure 16 Connecting via TB-68(Only for Full-Bridge)	43
Figure 17 Quarter-Bridge Type I Measuring Axial and Bending Strain	46
Figure 18 Quarter-Bridge Type I Circuit Diagram	46
Figure 19 Quarter-Bridge Type II Measuring Axial and Bending Strain	47

Figure 20 Quarter-Bridge Type II Circuit Diagram 48

Figure 21 Half-Bridge Type I Measuring Axial and Bending Strain 49

Figure 22 Half-Bridge Type I Circuit Diagram 50

Figure 23 Half-Bridge Type II Rejecting Axial and Measuring Bending Strain 51

Figure 24 Half-Bridge Type II Circuit Diagram 52

Figure 25 Full-Bridge Type I Rejecting Axial and Measuring Bending Strain 53

Figure 26 Full-Bridge Type I Circuit Diagram 54

Figure 27 Full-Bridge Type II Rejecting Axial and Measuring Bending Strain 55

Figure 28 Full-Bridge Type II Circuit Diagram 56

Figure 29 Full-Bridge Type III Measuring Axial and Rejecting Bending Strain 57

Figure 30 Full-Bridge Type III Circuit Diagram 58

Figure 31 Full-Bridge with TB-6313D Circuit Diagram 60

Figure 32 Full-Bridge with General Terminal Block Circuit Diagram 61

3. Introduction

This chapter presents the information how to use this manual and quick start if you are already familiar with Microsoft Visual Studio and C# programming language.

3.1 Overview

JY-6313 Is a high-density data acquisition module specially designed for high-precision strain measurement, integrating industry-leading strain measurement technology. The module provides up to 16 independent measurement channels and supports a wide-ranging input gain of inputs from x6.25 to x100, providing accurate capturing tiny strain signals. Its sampling rate of up to 80 kS/s ensures a rapid and continuous data acquisition capability, which is suitable for dynamic strain test scenarios. JY-6313 Not only has the PXIe interface version, but also provides the PCIe interface version, which enhances its application flexibility in different test systems. The module adopts the advanced 24-bit analog-to-digital converter (ADC), combined with high-precision hardware design and calibration process, to ensure the accuracy and reliability of the measurement results, and is an ideal choice in the fields of structural health monitoring, mechanics of materials research and industrial process control.

3.2 Abbreviations

- JY-6313: JYTEK PXIe-6313
- AI: Analog Input
- ADC: Analog to Digital Conversion
- PFI: Programmable Function Interface
- DIFF: Differential
- RS: Remote Sensing
- SC: Shunt Calibration

3.3 JYPEDIA and Learn by Example

JYPEDIA is an excel file, which contains JYTEK product information, pricing, inventory information, drivers, software, technical support, knowledge base etc. You can download a

[JYPEDIA](http://www.jytek.com) excel file from our web www.jytek.com. JYTEK highly recommends you use this file to obtain information from JYTEK.

Learn by Example is a unique feature in JYTEK product manual. In this manual, we provide many sample programs for this device. Open JYPEDIA and search for JY-6313 in the driver sheet, select **JY6313_Examples.zip**. This will lead you to download the sample program for this device.

To use **Learn by Example**, it is recommended to connect JY-6313 to strain gages with ACL-1016868-01 cable and TB-6313D terminal block. For more information about TB-6313D, please refer to chapter 6.3.

4. Hardware Specifications

This chapter provides the hardware specifications of JY-6313.

4.1 System Diagram

Figure 1 shows how JY-6313 is typically used to measure the voltage through bridge. A Wheatstone bridge sensor connects to JY-6313 in quarter-, half-, and full bridge configurations.

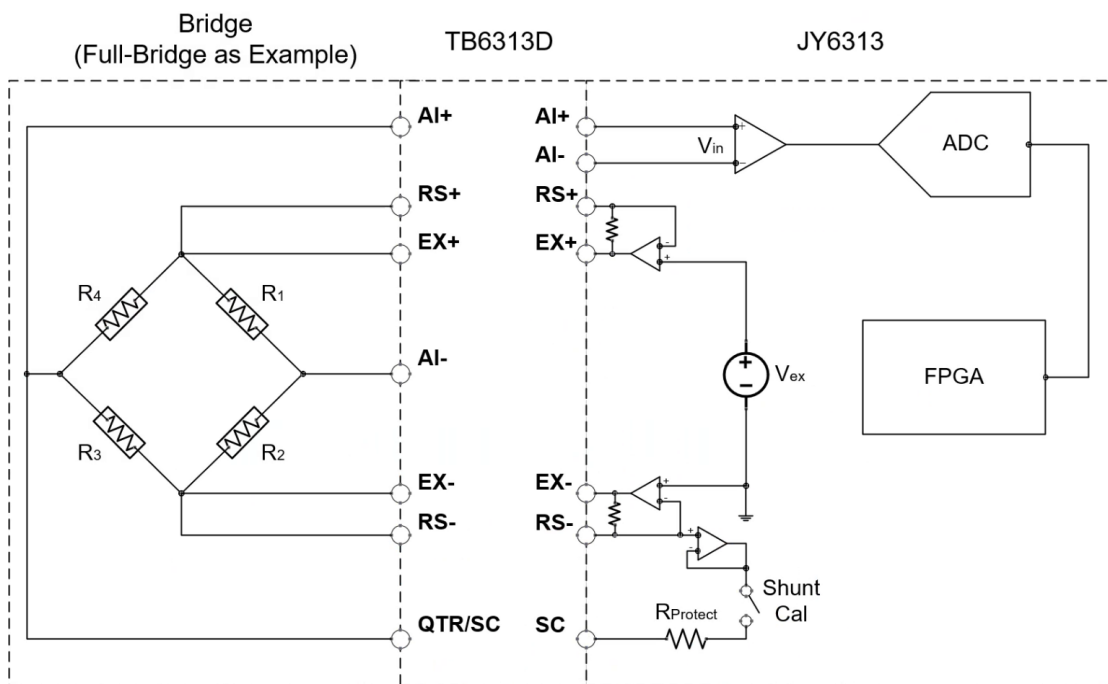

Figure 1 Full-Bridge Input and TB-6313D/JY-6313

The accuracy and resolution of the voltage measurement are determined by those Wheatstone bridge and strain-gage connected to JY-6313.

4.2 Front Panel

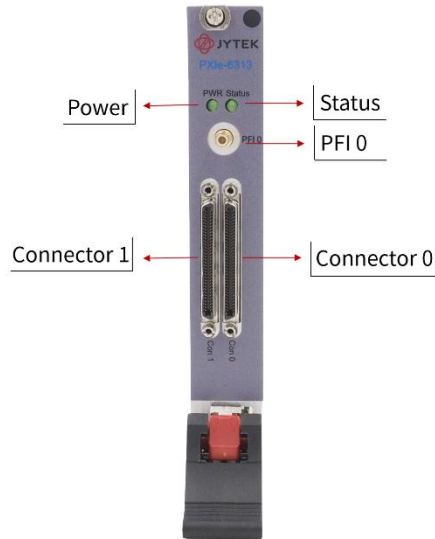

Figure 2 JY-6313 Front Panel

4.3 Pin Definition

JY-6313 provides 16 channels of strain measurements and 1 digital input channel (for digital triggering). Below Tables list the definitions of all pins on the front panel connectors.

Pin Name	Signal Description
AI+	Positive differential analog input.
AI-	Negative differential analog input.
RS+	Positive remote sensing input, optional. Connect this pin to the EX+ of the bridge to enable Remote Sensing function.
RS-	Negative remote sensing input, optional. Connect this pin to the EX- of the bridge to enable Remote Sensing function.
EX+	Positive excitation output.

EX-	Negative excitation output.
SC	Connection points for shunt calibration function.
NC	Null connection. Do not use these pins.
RSVD	Reserved pins for accessory (TB-6313D) or other functions. Do not use these pins.

Table 26 Front Panel Pinout Description

Connector1 (Left)

Pin	Signal	Pin	Signal
1	CH8_AI+	35	CH8_AI-
2	CH8_RS+	36	CH8_RS-
3	CH8_EX+	37	CH8_EX-
4	CH8_SC	38	NC
5	CH9_AI+	39	CH9_AI-
6	CH9_RS+	40	CH9_RS-
7	CH9_EX+	41	CH9_EX-
8	CH9_SC	42	NC
9	CH10_AI+	43	CH10_AI-
10	CH10_RS+	44	CH10_RS-
11	CH10_EX+	45	CH10_EX-
12	CH10_SC	46	NC
13	CH11_AI+	47	CH11_AI-
14	CH11_RS+	48	CH11_RS-
15	CH11_EX+	49	CH11_EX-
16	CH11_SC	50	NC
17	CH12_AI+	51	CH12_AI-
18	CH12_RS+	52	CH12_RS-
19	CH12_EX+	53	CH12_EX-
20	CH12_SC	54	NC
21	CH13_AI+	55	CH13_AI-
22	CH13_RS+	56	CH13_RS-
23	CH13_EX+	57	CH13_EX-
24	CH13_SC	58	NC
25	CH14_AI+	59	CH14_AI-
26	CH14_RS+	60	CH14_RS-
27	CH14_EX+	61	CH14_EX-
28	CH14_SC	62	NC
29	CH15_AI+	63	CH15_AI-
30	CH15_RS+	64	CH15_RS-
31	CH15_EX+	65	CH5_EX-
32	CH15_SC	66	NC
33	GND	67	RSVD
34	RSVD	68	RSVD

Connector0 (Right)

Pin	Signal	Pin	Signal
1	CH0_AI+	35	CH0_AI-
2	CH0_RS+	36	CH0_RS-
3	CH0_EX+	37	CH0_EX-
4	CH0_SC	38	NC
5	CH1_AI+	39	CH1_AI-
6	CH1_RS+	40	CH1_RS-
7	CH1_EX+	41	CH1_EX-
8	CH1_SC	42	NC
9	CH2_AI+	43	CH2_AI-
10	CH2_RS+	44	CH2_RS-
11	CH2_EX+	45	CH2_EX-
12	CH2_SC	46	NC
13	CH3_AI+	47	CH3_AI-
14	CH3_RS+	48	CH3_RS-
15	CH3_EX+	49	CH3_EX-
16	CH3_SC	50	NC
17	CH4_AI+	51	CH4_AI-
18	CH4_RS+	52	CH4_RS-
19	CH4_EX+	53	CH4_EX-
20	CH4_SC	54	NC
21	CH5_AI+	55	CH5_AI-
22	CH5_RS+	56	CH5_RS-
23	CH5_EX+	57	CH5_EX-
24	CH5_SC	58	NC
25	CH6_AI+	59	CH6_AI-
26	CH6_RS+	60	CH6_RS-
27	CH6_EX+	61	CH6_EX-
28	CH6_SC	62	NC
29	CH7_AI+	63	CH7_AI-
30	CH7_RS+	64	CH7_RS-
31	CH7_EX+	65	CH7_EX-
32	CH7_SC	66	NC
33	GND	67	RSVD
34	RSVD	68	RSVD

Table 27 Front Panel Pinout Definition

Please refer to Section 6.3 when connecting via TB-6313D.

TB-6313D has 4 DB15 ports on the front, each DB15 port contains two channels, each channel uses 7 wires, and one wire is for grounding, as shown in Figure 5 , the definitions of the 15 pins are shown in Table 28.

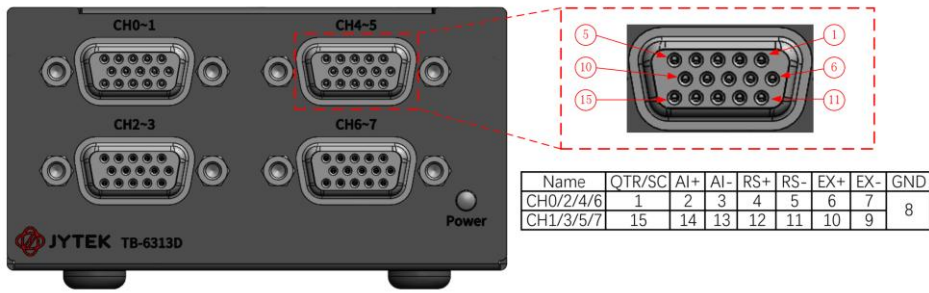

Figure 3 The front of TB-6313D

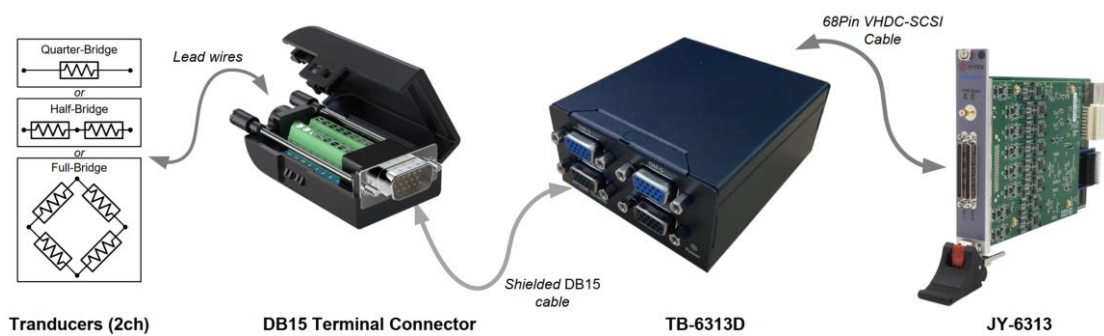

Figure 4 The front of TB-6313D

The definition of the DB15pin converter's pins is as shown in Table 28.

Pin	Name	Description
2/14	AI+	Positive differential analog input.
3/13	AI-	Negative differential analog input.
4/12	RS+	Positive remote sensing input.
6/10	EX+	Positive excitation output.
7/9	EX-	Negative excitation output.
5/11	RS-	Negative remote sensing input
1/15	QTR/SC	The quarter-bridge connection point or shunt calibration connection point depends on the strain configuration.
8	GND	Connect to the terminal box ground.

Table 28 TB-6313D DB15 Pinout Definition

4.4 Gain and Offset Errors

An instrument's accuracy is defined by the gain and offset errors as follows:

$$\text{Accuracy} = \text{Gain Error (\% of reading)} + \text{Offset Error (\% of range)}.$$

Equation 1 Gain and Offset Errors

It should be noted when the reading is close to zero, the gain error is very small and negligible, the offset error is dominant; when the reading is getting close to the full range, the gain error becomes more significant.

4.5 Ratiometric (mV/V) Measurement Accuracy

The basic ratiometric measurement accuracy of JY-6313 is shown in [错误!未找到引用源。](#)

*V_{ex}: Bridge excitation voltage

4.6 Example of Calculating Gain and Offset Errors

The following example explains how to calculate total gain and offset errors based on a given excitation voltage V_{ex} and the respective formulae for error percentages.

For an excitation voltage $V_{ex} = 5\text{ V}$, the offset error is calculated as:

$$\text{Offset Error} = 280/V_{ex} = \frac{280}{5} = 56\ \mu\text{V/V}$$

To express this offset error as a percentage of the full-scale range, assume a full-scale range of $80,000\ \mu\text{V}$:

$$\text{Percentage Error} = \frac{56}{80000} = 0.07\%$$

This calculation demonstrates how the offset error changes according to V_{ex} and affects the overall measurement accuracy. See below Table 29, example of $V_{ex} = 5\text{ V}$ for all Input Gain.

Input Gain (mV/V)	Ratiometric Range (Vex = 5V)	Gain Error (% of Reading)	Offset Error (% of Reading)
6.25	±80 mV/V	0.03	0.07
12.5	±40 mV/V	0.03	0.09
25	±20 mV/V	0.03	0.15
50	±10 mV/V	0.03	0.28
100	±5 mV/V	0.04	0.56

Table 29 Calculating Gain and Offset Errors

5. Software

5.1 System Requirements

JY-6313 boards can be used in a Windows or Linux operating system.

Microsoft Windows: Windows 7 32/64 bit, Windows 10 32/64 bit.

Linux Kernel Versions: There are many Linux versions. It is not possible JYTEK can support and test our devices under all different Linux versions. JYTEK will at the best support the following Linux versions.

Linux Version	
Ubuntu LTS	
16.04:	4.4.0-21-generic(desktop/server)
16.04.6:	4.15.0-45-generic(desktop) 4.4.0-142-generic(server)
18.04:	4.15.0-20-generic(desktop) 4.15.0-91-generic(server)
18.04.4:	5.3.0-28-generic (desktop) 4.15.0-91-generic(server)
Localized Chinese Version	
中标麒麟桌面操作系统软件（兆芯版）V7.0（Build61）: 3.10.0-862.9.1.nd7.zx.18.x86_64	
中标麒麟高级服务器操作系统软件V7.0U6: 3.10.0-957.el7.x86_64	

Table 30 Supported Linux Versions

5.2 System Software

When using the JY-6313 in the Window environment, you need to install the following software from Microsoft website:

Microsoft Visual Studio Version 2015 or above,

.NET Framework version is 4.0 or above.

.NET Framework is coming with Windows 10. For Windows 7, please check the .NET Framework version and upgrade to 4.0 or later version.

Given the resources limitation, JYTEK only tested JY-6313 be with .NET Framework 4.0 with Microsoft Visual Studio 2015. JYTEK relies on Microsoft to maintain compatibility for the newer versions.

5.3 C# Programming Language

All JYTEK default programming language is Microsoft C#. This is Microsoft recommended programming language in Microsoft Visual Studio and is particularly suitable for the test and measurement applications. C# is also a cross-platform programming language.

5.4 JY-6313 Hardware Driver

After installing the required application development environment as described above, you need to install the JY-6313 hardware driver.

JYTEK hardware driver has two parts: the shared common driver kernel software (FirmDrive) and the specific hardware driver.

Common Driver Kernel Software (FirmDrive): FirmDrive is JYTEK's kernel software for all hardware products of JYTEK instruments. You need to install the FirmDrive software before using any other JYTEK hardware products. FirmDrive only needs to be installed once. After that, you can install the specific hardware driver.

Specific Hardware Driver: Each JYTEK hardware has a C# specific hardware driver. This driver provides rich and easy-to-use C# interfaces for users to operate various JY-6313 function. JYTEK has standardized the ways which JYTEK and other vendor's DAQ boards are used by providing a consistent user interface, using the methods, properties and enumerations in the object-oriented programming environment. Once you get yourself familiar with how one JYTEK DAQ card works, you should be able to know how to use all other DAQ hardware by using the same methods.

Note that this driver does not support cross-process, and if you are using more than one function, it is best to operate in one process.

5.5 Install the SeeSharpTools from JYTEK

To efficiently and effectively use JY-6313 boards, you need to install a set of free C# utilities, SeeSharpTools from JYTEK. The SeeSharpTools offers rich user interface functions you will find convenient in developing your applications. They are also needed to run the examples come with JY-6313 hardware. Please register and download the latest SeeSharpTools from our website, www.jytek.com.

5.6 Running C# Programs in Linux

Most C# written programs in Windows can be run by MonoDevelop development system in a Linux environment. You would develop your C# applications in Windows using Microsoft Visual Studio. Once it is done, run this application in the MonoDevelop environment. This is

JYTEK recommended way to run your C# programs in a Linux environment.

If you want to use your own Linux development system other than MonoDevelop, you can do it by using our Linux driver. However, JYTEK does not have the capability to support the Linux applications. JYTEK completely relies upon Microsoft to maintain the cross-platform compatibility between Windows and Linux using MonoDevelop.

6. Connecting Wheatstone Bridge

This chapter describes the basic principles of Wheatstone Bridges, the options used to correct for resistance errors, and how to connect strain gages to JY6313 in various strain gage configurations.

6.1 Wheatstone Bridge

The Wheatstone bridge is a fundamental setup for sensors such as strain gauges, load cells, pressure sensors, and torque sensors. A typical Wheatstone bridge consists of four components or "arms," which are generally resistive, although reactive elements can also be used. Most bridge-based sensors rely on all four arms for active sensing, but configurations with one, two, or four active sensing elements are also common. Figure illustrates a standard resistive Wheatstone bridge circuit.

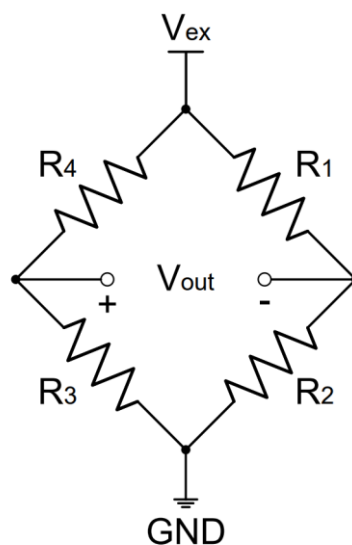

Figure 5 Wheatstone Bridge

The Wheatstone bridge functions as two parallel voltage divider circuits: R1 and R2 form one divider, while R3 and R4 make up the second. The bridge's output is measured between the center nodes of these dividers. When subjected to physical phenomena like strain or temperature changes, the sensing elements in the bridge alter in resistance, creating a bridge output voltage that reflects these changes. This output scales with the excitation voltage.

However, regardless of changes in excitation voltage, the ratio of bridge output (V_{out}) to excitation voltage (V_{ex}) remains constant, making this dimensionless ratio (V_{out}/V_{ex}) the key measurement factor. To accurately measure this ratiometric output, both the bridge output (V_{out}) and excitation voltage (V_{ex}) need to be determined. This can be done by using an accurate voltage source or measuring the voltage. The JY-6313 module includes a high-precision, factory-calibrated excitation source capable of compensating for voltage drops in lead wires, ensuring that the bridge receives an excitation voltage very close to the target voltage.

6.2 Options to Correct for Resistance Errors

The basic Wheatstone bridge circuit, shown in Figure 5, omits the specific wiring needed to connect sensors to an instrument. However, resistance in lead wires can cause offset and gain errors, as illustrated in Figure 6.

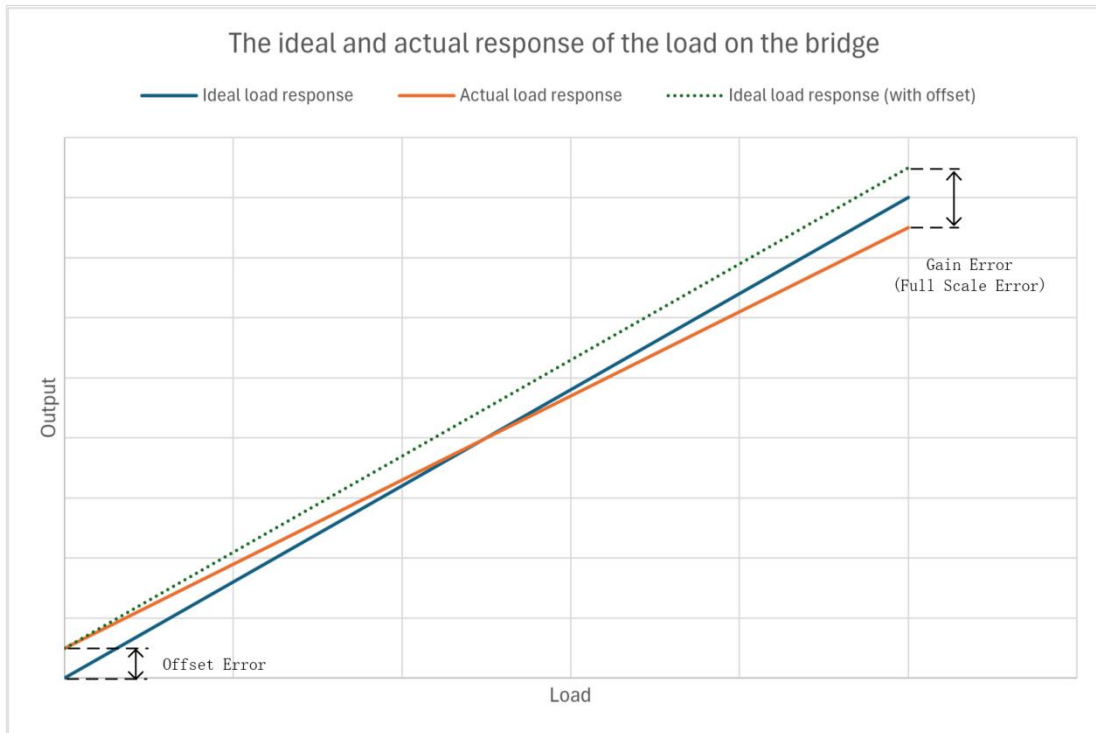

Figure 6 Ideal and Actual Load Response on the Bridge

The JY-6313 module provides three methods to correct these errors: remote sensing, offset nulling, and shunt calibration.

6.2.1 Remote Sensing

The resistance in the wires connecting the bridge to the excitation source can result in a voltage drop, as shown in Figure 7.

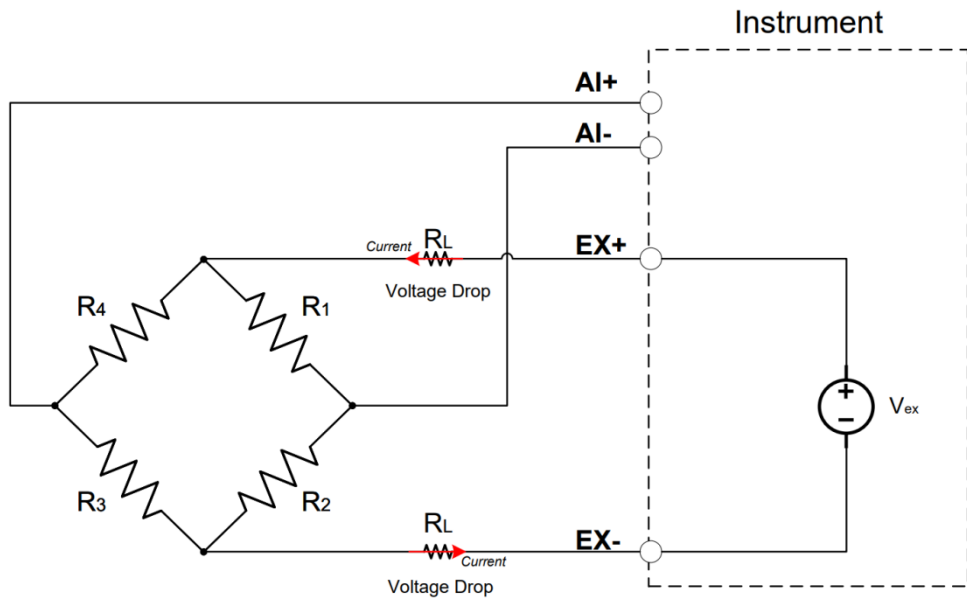

Figure 7 Voltage Drop Due to Lead Resistance

The actual excitation voltage at the bridge is lower than the sourced voltage at the EX+ and EX- connectors. This voltage drop reduces the bridge output, causing the measured strain values to be less than the true values.

The JY-6313 module offers a Remote Sensing feature to correct errors introduced by excitation lead resistance. To utilize this, connect the remote sensing inputs of the JY-6313 as close to the bridge circuit as possible, as shown in the full-bridge diagram in Figure 8.

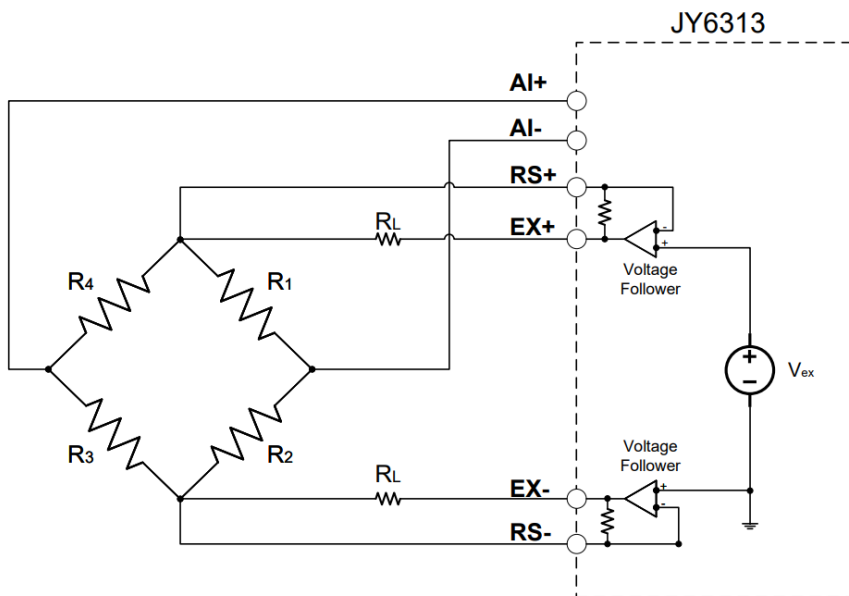

Figure 8 Connecting Remote Sensing to JY-6313

Once connected, the voltage followers within JY-6313 use high-impedance RS wires to sense the actual excitation voltage at the bridge, compensating the excitation output to ensure accurate voltage across the bridge. This correction operates continuously and is most beneficial for half- and full-bridge sensors, particularly when long or small-gauge wires are used due to their higher resistance.

6.2.2 Offset Nulling

Ideally, the bridge output should be 0V with no load. However, resistance differences among bridge legs can produce a non-zero offset.

The JY-6313 module compensates for offset errors using integrated voltage generators that provide both coarse and fine adjustments. The coarse offset ranges from -100mV to +100mV with a 1mV resolution, and after initial signal amplification (selectable between x4 to x64), a fine offset adjustment of -400mV to ± 400 mV, with approximately 38 μ V resolution, is applied before reaching the ADC. Figure 9 illustrates this process.

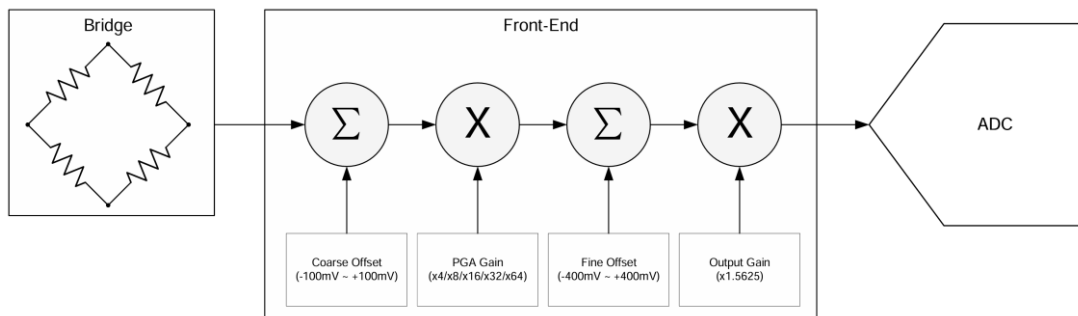

Figure 9 Hardware Offset Nulling Process

To use offset nulling, call `JY6313AITask.PerformOffsetNulling()` before data acquisition. The module will adjust offsets multiple times to bring the ADC reading as close to 0V as possible or until offset limits are reached. Ensure the bridge remains stable during this process, as duration varies with the sampling rate. Data acquisition can begin once offset nulling is complete, or shunt calibration may be performed first.

6.2.3 Shunt Calibration

While remote sensing compensates for EX lead resistance, shunt calibration corrects for this and any resistance within a bridge arm.

Shunt calibration simulates a gauge input by changing an arm's resistance by a known amount, typically achieved by connecting a known resistor (R_{SC}) across one arm, as shown in Figure 10, causing a predictable bridge output change.

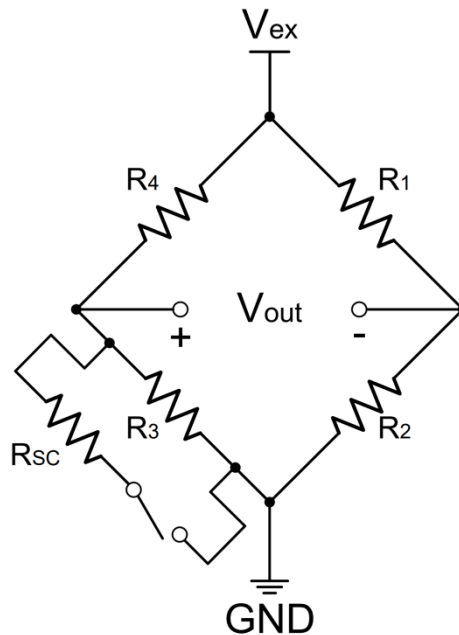

Figure 10 Shunt Calibration Diagram

The measured change can be compared to expected values to correct gain errors across the entire measurement path or validate setup operation. Shunt calibration is particularly effective for three-wire quarter-bridge sensors with significant wiring resistance where remote sensing is unavailable. Refer to Figure 18 for setup details.

JY-6313's shunt calibration includes a software-controlled switch and shunt calibration resistors on the TB-6313D blocks. Call `JY6313AITask.PerformShuntCalibration()` before data acquisition. The module automatically calculates a gain adjustment coefficient by measuring strain pre- and post-shunt, compensating for subsequent measurements. Ensure bridge stability during calibration, as duration depends on the sample rate.

If both offset nulling and shunt calibration are needed, perform offset nulling first, followed by shunt calibration, before starting data acquisition.

6.3 Using Terminal Block TB-6313D

TB-6313D is a dedicated terminal block for JY-6313, as shown in

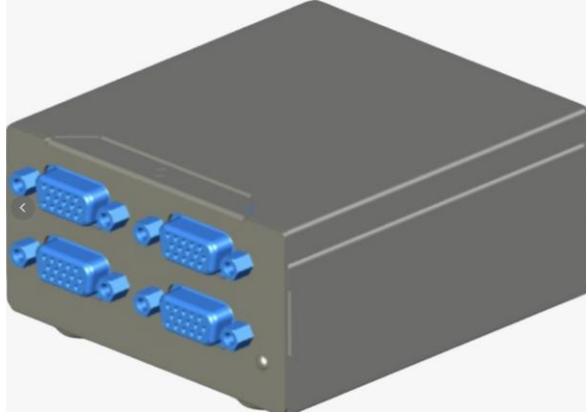

Figure 11 .Each TB-6313D can provide 8 transducer channels, Ch0 to Ch7.

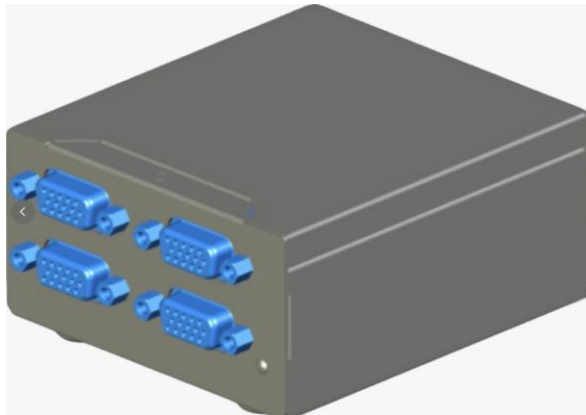

Figure 11 TB-6313D

TB-6313D provides three main functions:

- Connect transducer to JY-6313 more conveniently.
- Completing the bridge, users can use just one or two strain gages to form one or two bridge arms when measuring strain, and TB-6313D can complete the remaining bridge arms. Moreover, the 1/4 bridge completion resistor can be selected with resistance values of 120 Ω , 350 Ω , or 1000 Ω to accommodate strain gages with different nominal resistances.
- TB-6313D internally integrates two shunt resistors with resistances of 50k Ω and 100k Ω . To use shunt calibration function, users only need to connect the SC pin to the

corresponding position of the Wheatstone bridge with a single lead wire, and the JY-6313 will automatically select the appropriate shunt resistor.

TB-6313D has 4 DB15 ports on the front, each DB15 port contains two channels, each channel uses 7 wires, and one wire is for grounding, as shown in Figure 12, the definitions of the 15 pins are shown in Table 31.

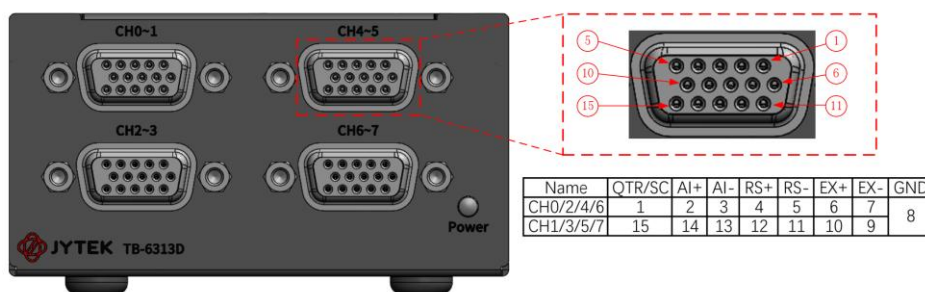

Figure 12 The front of TB-6313D

The definition of the DB15 converter's pins is as shown in Table 31.

Pin	Name	Description
2/14	AI+	Positive differential analog input.
3/13	AI-	Negative differential analog input.
4/12	RS+	Positive remote sensing input.
6/10	EX+	Positive excitation output.
7/9	EX-	Negative excitation output.
5/11	RS-	Negative remote sensing input
1/15	QTR/SC	The quarter-bridge connection point or shunt calibration connection point depends on the strain configuration.
8	GND	Connect to the terminal box ground.

Table 31 TB-6313D DB15 Pinout Definition

On the back of the TB-6313D, there is a 68-pin SCSI connector as shown in Figure 13, used to connect to the JY-6313 via a VHDC-SCSI cable.

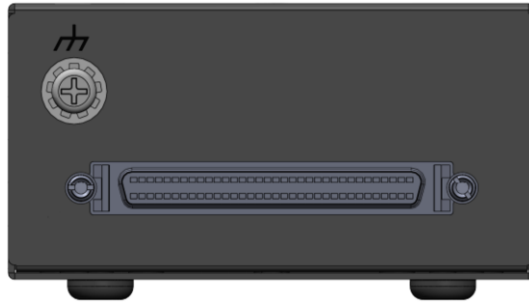

Figure 13 The back of TB-6313D

When connecting transducer to JY-6313 via TB-6313D, you can first connect the transducer to the pins of an converter, and then connect the converter to the TB-6313D with an cable, as shown in Figure 14. The pin definition still refers to Table 31.

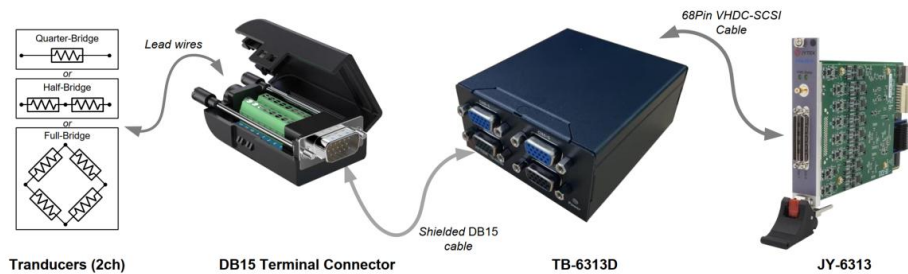

Figure 14 Connecting via TB-6313D

It is strongly recommended to use shielded cables because when the transducer is a quarter-bridge or half-bridge, the AI+ and AI- wires cannot form a twisted pair, which prevents the cancellation of electromagnetic interference. The shielding layer of the cable can effectively shield against such interference.

When connecting a quarter-bridge or half-bridge, the TB-6313D is mandatory; when connecting a full- bridge, TB-6313D is optional. However, in either case, you need to inform JY-6313 whether the TB-6313D has been used, as the JY-6313 needs to know this information to determine whether to configure the terminal block.

In the following chapter 6.5 (Strain Gage Configurations), it will be assumed that the strain gages are connected via TB-6313D by default.

6.4 Using Terminal Block TB-68

TB-68 is a terminal block with a standardized 68-pin interface, as shown in Figure xx. JY-6313



can be used with the TB-68 for full-bridge strain measurement. Each TB-68 terminal block can connect up to 8 strain transducer channels.

Figure 15 TB-68

TB-68 provides follow main function:

TB-68 only supports a full bridge strain configuration. Users need to use four strain gages to form a complete Wheatstone bridge for optimal measurement accuracy and stability.

The module wiring method is shown in Figure 16.

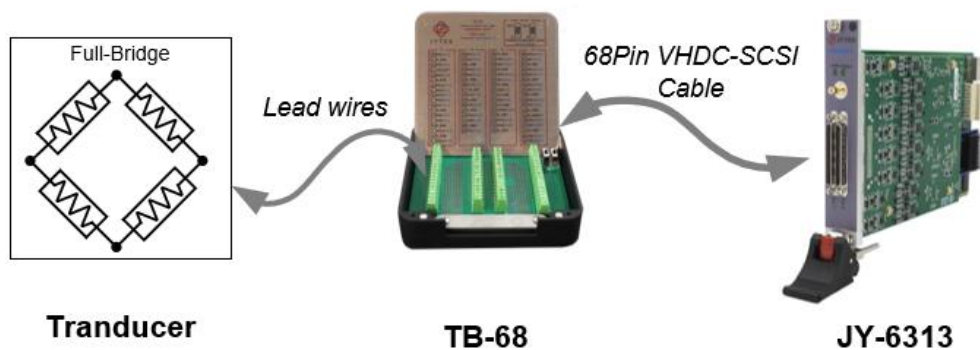

Figure 16 Connecting via TB-68(Only for Full-Bridge)

Every 8 pins on the TB-68 consists of one strain measurement channel. The pin definition is shown in Table 32.

Connector1 (Left)				Connector0 (Right)			
Pin	Signal	Pin	Signal	Pin	Signal	Pin	Signal
1	CH8_AI+	35	CH8_AI-	1	CH0_AI+	35	CH0_AI-
2	CH8_RS+	36	CH8_RS-	2	CH0_RS+	36	CH0_RS-
3	CH8_EX+	37	CH8_EX-	3	CH0_EX+	37	CH0_EX-
4	CH8_SC	38	NC	4	CH0_SC	38	NC
5	CH9_AI+	39	CH9_AI-	5	CH1_AI+	39	CH1_AI-
6	CH9_RS+	40	CH9_RS-	6	CH1_RS+	40	CH1_RS-
7	CH9_EX+	41	CH9_EX-	7	CH1_EX+	41	CH1_EX-
8	CH9_SC	42	NC	8	CH1_SC	42	NC
9	CH10_AI+	43	CH10_AI-	9	CH2_AI+	43	CH2_AI-
10	CH10_RS+	44	CH0_RS-	10	CH2_RS+	44	CH2_RS-
11	CH10_EX+	45	CH10_EX-	11	CH2_EX+	45	CH2_EX-
12	CH10_SC	46	NC	12	CH2_SC	46	NC
13	CH11_AI+	47	CH11_AI-	13	CH3_AI+	47	CH3_AI-
14	CH11_RS+	48	CH11_RS-	14	CH3_RS+	48	CH3_RS-
15	CH11_EX+	49	CH11_EX-	15	CH3_EX+	49	CH3_EX-
16	CH11_SC	50	NC	16	CH3_SC	50	NC
17	CH12_AI+	51	CH12_AI-	17	CH4_AI+	51	CH4_AI-
18	CH12_RS+	52	CH12_RS-	18	CH4_RS+	52	CH4_RS-
19	CH12_EX+	53	CH12_EX-	19	CH4_EX+	53	CH4_EX-
20	CH12_SC	54	NC	20	CH4_SC	54	NC
21	CH13_AI+	55	CH13_AI-	21	CH5_AI+	55	CH5_AI-
22	CH13_RS+	56	CH13_RS-	22	CH5_RS+	56	CH5_RS-
23	CH13_EX+	57	CH13_EX-	23	CH5_EX+	57	CH5_EX-
24	CH13_SC	58	NC	24	CH5_SC	58	NC
25	CH14_AI+	59	CH14_AI-	25	CH6_AI+	59	CH6_AI-
26	CH14_RS+	60	CH14_RS-	26	CH6_RS+	60	CH6_RS-
27	CH14_EX+	61	CH14_EX-	27	CH6_EX+	61	CH6_EX-
28	CH14_SC	62	NC	28	CH6_SC	62	NC
29	CH15_AI+	63	CH15_AI-	29	CH7_AI+	63	CH7_AI-
30	CH15_RS+	64	CH15_RS-	30	CH7_RS+	64	CH7_RS-
31	CH15_EX+	65	CH5_EX-	31	CH7_EX+	65	CH7_EX-
32	CH15_SC	66	NC	32	CH7_SC	66	NC
33	GND	67	RSVD	33	GND	67	RSVD
34	RSVD	68	RSVD	34	RSVD	68	RSVD

Table 32 Front Panel Pin Definition

6.5 Strain Gage Configurations

This section describes the setup and connection types for different strain gage

configurations.

The JY-6313 module supports three bridge circuit configurations: quarter-bridge, half-bridge, and full-bridge.

A quarter-bridge circuit consists of one active strain gauge element and three fixed resistors. It is widely used for simplicity. A typical quarter-bridge setup is shown in Figure 18.

Temperature fluctuations can affect accuracy, so a dummy gauge may be used to counteract temperature effects, as shown in Figure 19.

In a half-bridge circuit with two active strain gauge elements, axial or bending strain can be measured. The first type uses one element along the axial strain direction and another as a Poisson gauge perpendicular to the strain axis as shown in Figure 21. Another type measures only bending strain, with one element positioned on each side of the specimen (top and bottom), as shown in Figure 23.

A full-bridge circuit with four active strain gauge elements measures bending or axial strain. The first type of full-bridge circuit (Full-Bridge Type I, see Figure 25) measures bending strain, with two elements on each side of the specimen, providing double the sensitivity of Half-Bridge Type II. The second type (Full-Bridge Type II, see Figure 27) measures bending strain using two elements along the bending direction and two acting as Poisson gauges perpendicular to the strain axis. The third type (Full-Bridge Type III, see Figure 29) measures axial strain, with two elements in the axial direction and two Poisson gauges transverse to the strain axis, similar to Half-Bridge Type I.

6.5.1 Quarter-Bridge Type I

Quarter-Bridge Type I measures either axial or bending strain. Figure 17 shows the resistor positioning, and Figure 18 displays the wiring diagram. TB-6313D must be used in this configuration.

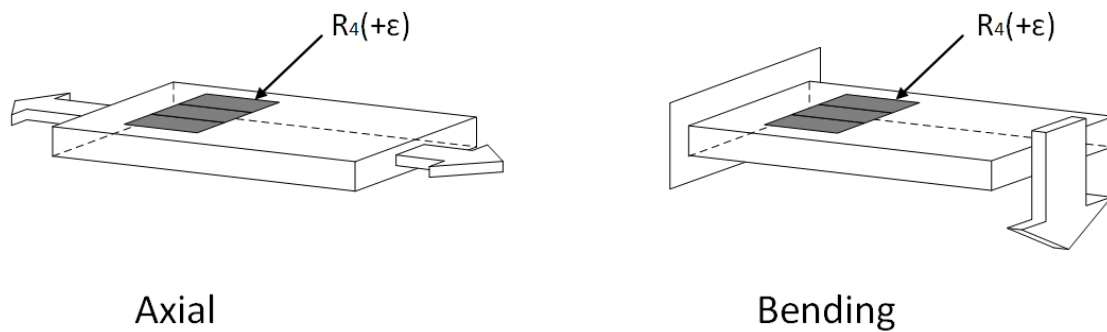

Figure 17 Quarter-Bridge Type I Measuring Axial and Bending Strain

Key features of Quarter-Bridge Type I:

- One active strain gauge in the principal axial or bending direction.
- A passive quarter-bridge completion resistor (R_3) alongside half-bridge completion resistors (R_1 and R_2) from the TB-6313D block.
- Shunt calibration resistor (R_{SC}) and Shunt Cal switch from the JY-6313.
- Sensitivity: $\sim 0.5\mu\text{V/V}$ per $\mu\epsilon$, for $GF = 2.0$.

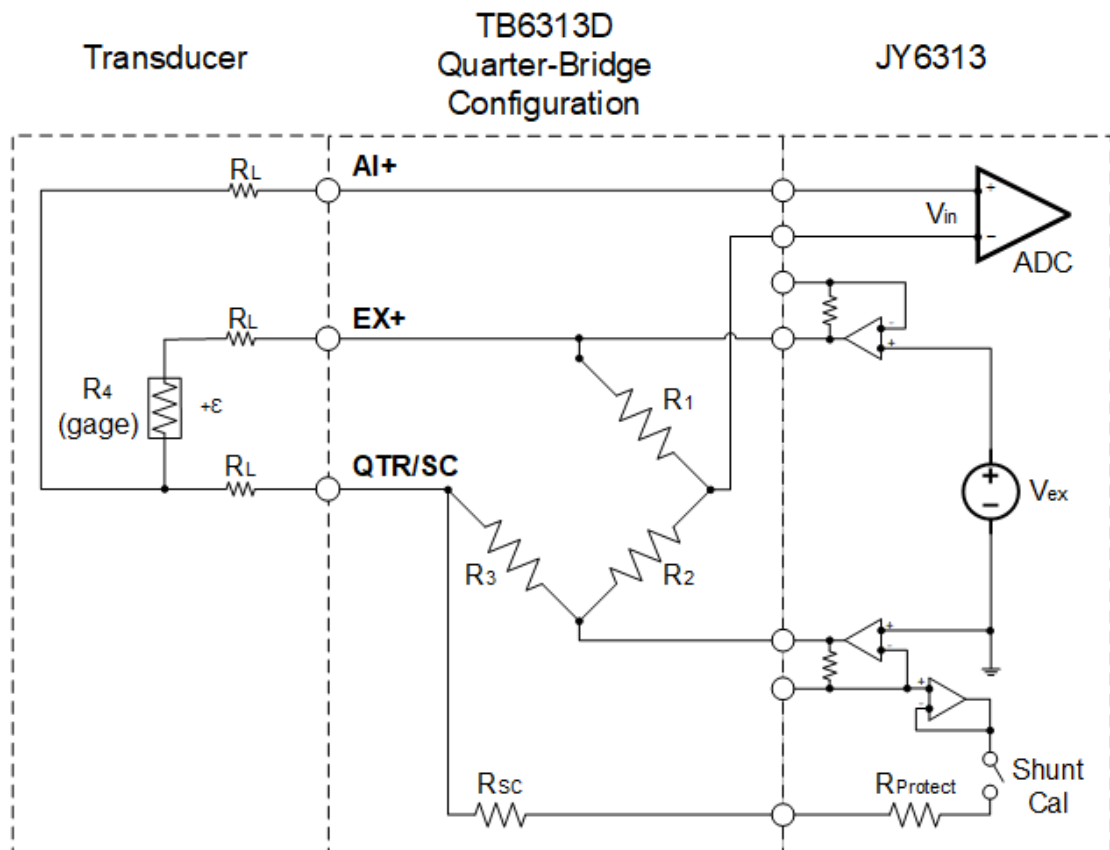

Figure 18 Quarter-Bridge Type I Circuit Diagram

Diagram symbols and equations:

- R_1, R_2 : Half-bridge completion resistors in TB-6313D.
- R_3 : Quarter-bridge completion resistor in TB-6313D.
- R_{SC} — Shunt calibration resistor located inside the TB-6313D.
- R_4 — Active element for tensile strain ($+\epsilon$).

- R_L — Lead resistance matching EX+ and QTR field wiring.
- GF — Gage Factor.
- V_{in} — Measured and excitation voltages.
- V_{ex} — Measured and excitation voltages.
- $R_{Protect}$ — 10kΩ resistor with Shunt Cal switch, total resistance with R_SC.
- e — Ratiometric output:

$$e = \frac{V_{in}}{V_{ex}}$$

Strain conversion formula:

$$\varepsilon = \frac{-4e}{GF(1 + 2e)}$$

To compensate for lead resistance errors, use shunt calibration.

6.5.2 Quarter-Bridge Type II

Quarter-Bridge Type II measures axial or bending strain. Figure 19 shows resistor positioning, and Figure 20 displays the wiring. TB-6313D must be used in this configuration. TB-6313D must be used in this configuration.

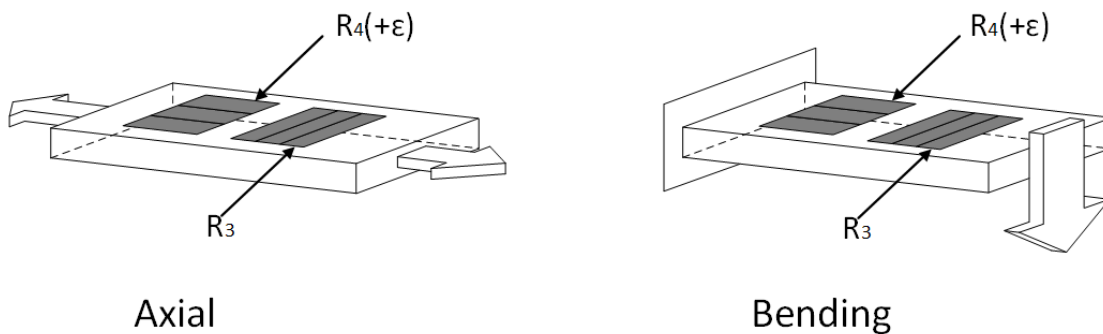

Figure 19 Quarter-Bridge Type II Measuring Axial and Bending Strain

Key features of Quarter-Bridge Type II:

- One active and one dummy gauge for temperature compensation.
- Half-bridge completion resistors in TB-6313D.

- Sensitivity: $\sim 0.5\mu\text{V/V}$ per $\mu\epsilon$, for $GF = 2.0$.

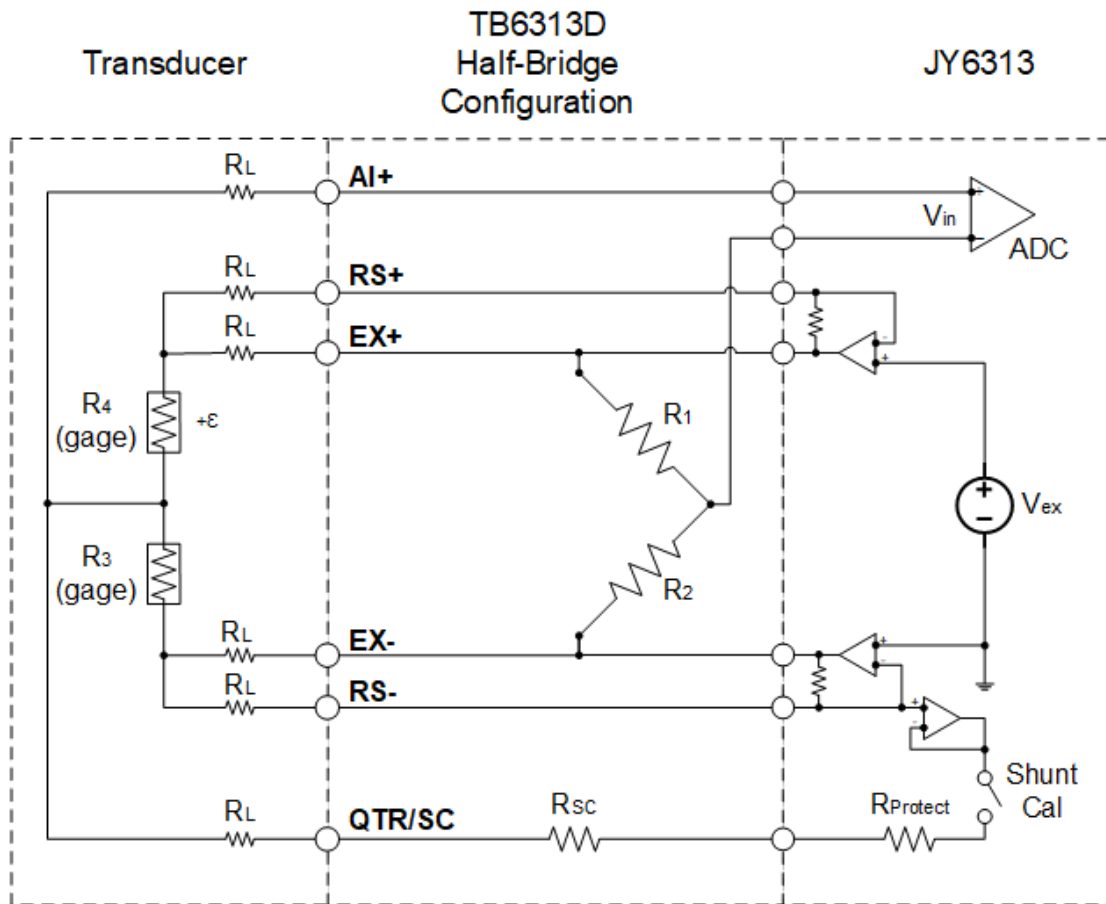

Figure 20 Quarter-Bridge Type II Circuit Diagram

Diagram symbols and equations:

- R_1 and R_2 —Half-bridge resistors in TB-6313D.
- R_3 —Quarter-bridge completion resistor located in close thermal contact with the active gage. R_3 must be equal to the nominal resistance of the active gage (R_4).
- R_{sc} —Shunt calibration resistor located inside the TB-6313D.
- R_4 —Active element measuring tensile strain ($+\epsilon$).
- R_L —Lead resistance.
- GF —Gage Factor, specified by the gage manufacturer.
- V_{in} —Measured voltage of the bridge.
- V_{ex} —Excitation voltage provided by the JY-6313.

- $R_{Protect}$ —10kΩ resistor in series with the Shunt Cal switch to protect against external fault voltages. The total shunt cal resistance is equal to the R_{SC} and $R_{Protect}$ series combination.
- e —ratiometric bridge output defined by the following equation:

$$e = \frac{V_{in}}{V_{ex}}$$

Strain conversion formula:

$$\varepsilon = \frac{-4e}{GF(1 + 2e)}$$

6.5.3 Half-Bridge Type I

Half-Bridge Type I measures axial or bending strain. See Figure 21 and Figure 22 for configurations and wiring. TB-6313D must be used in this configuration.

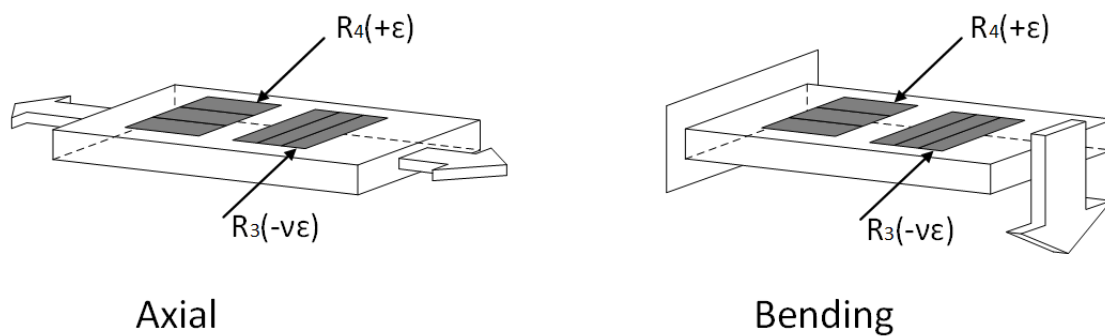

Figure 21 Half-Bridge Type I Measuring Axial and Bending Strain

A half-bridge type I has the following characteristics:

- Two active strain-gage elements. One strain-gage element is mounted in the direction of axial strain while the other acts as a Poisson gage and is mounted perpendicular to the principal axis of strain.
- Half-bridge completion resistors (R_1 and R_2) are provided by TB-6313D.
- Sensitive to both axial and bending strain.
- Sensitivity $\sim 0.65\mu\text{V}/\text{V}$ per $\mu\varepsilon$, for $GF = 2.0$.

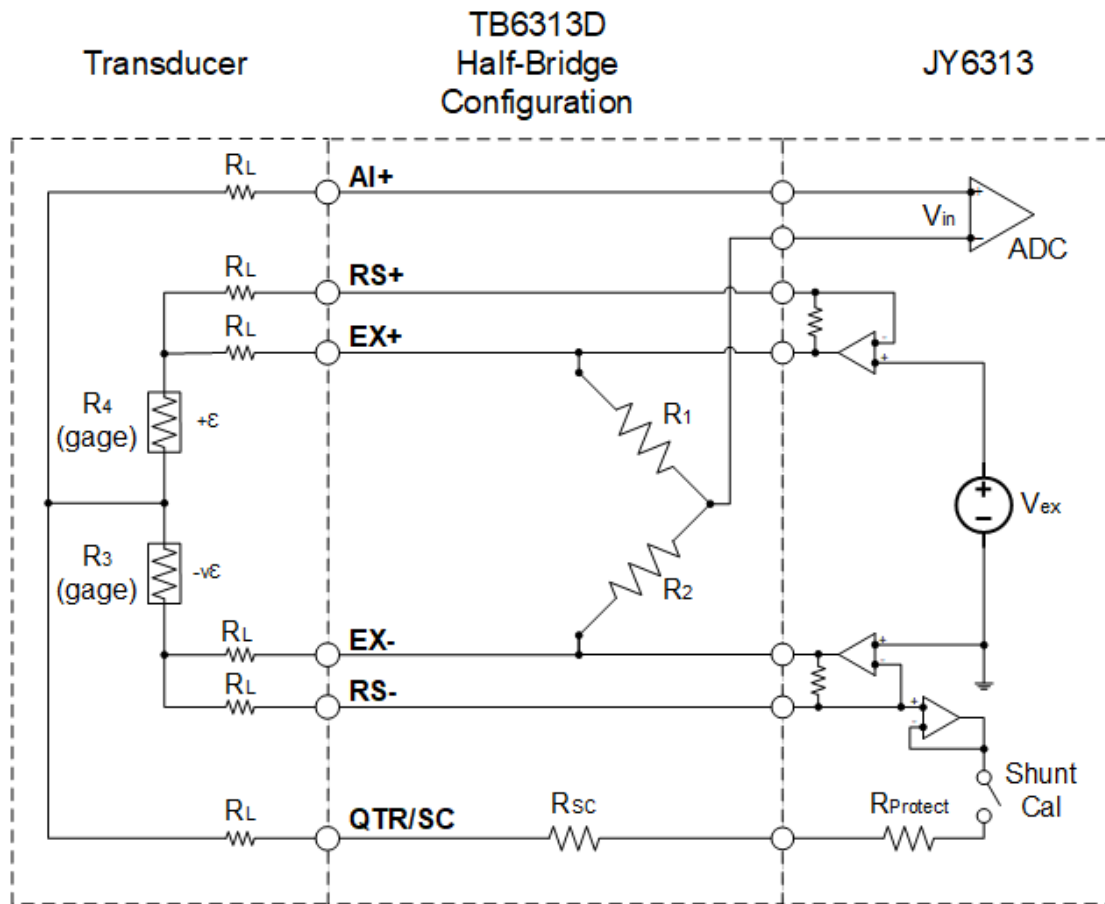

Figure 22 Half-Bridge Type I Circuit Diagram

The following symbols apply to the circuit diagram and equations:

- R_1 and R_2 —Half-bridge completion resistors located inside the TB-6313D.
- R_3 —Active element measuring compression from Poisson effect ($-\nu\epsilon$).
- R_{sc} —Shunt calibration resistor located inside the TB-6313D.
- R_4 —Active element measuring tensile strain ($+\epsilon$).
- R_L —Lead resistance.
- GF —Gage Factor, specified by the gage manufacturer.
- ν —Poisson’s ratio, defined as the negative ratio of transverse strain to axial strain (longitudinal) strain. Poisson’s ratio is a material property of the specimen you are measuring.
- V_{in} —Measured voltage of the bridge.
- V_{ex} —Excitation voltage provided by JY-6313.

- $R_{Protect}$ —10kΩ resistor in series with the Shunt Cal switch to protect against external fault voltages. The total shunt cal resistance is equal to the R_{SC} and $R_{Protect}$ series combination.
- e —ratiometric bridge output defined by the following equation:

$$e = \frac{V_{in}}{V_{ex}}$$

Strain conversion formula:

$$\varepsilon = \frac{-4e}{GF[(1 + \nu) - 2e(\nu - 1)]}$$

6.5.4 Half-Bridge Type II

The Half-Bridge Type II configuration is designed exclusively for measuring bending strain. Refer to Figure 23 and Figure 24 for setup details. TB-6313D must be used in this configuration.

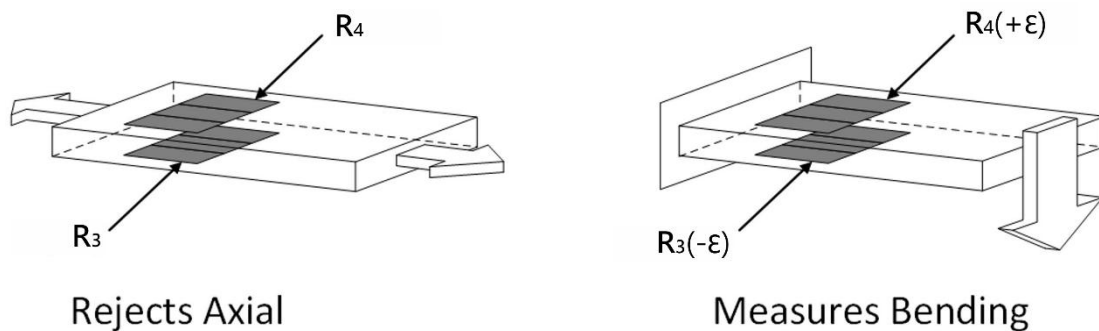

Figure 23 Half-Bridge Type II Rejecting Axial and Measuring Bending Strain

A half-bridge type II configuration has the following characteristics:

- Two active strain gauges mounted for bending strain: one on each side of the specimen (top and bottom).
- Half-bridge completion resistors provided by the TB-6313D.
- Sensitive to bending strain and rejects axial strain.
- Sensitivity $\sim 1\mu\text{V}/\text{V}$ per $\mu\epsilon$, for $GF = 2.0$.

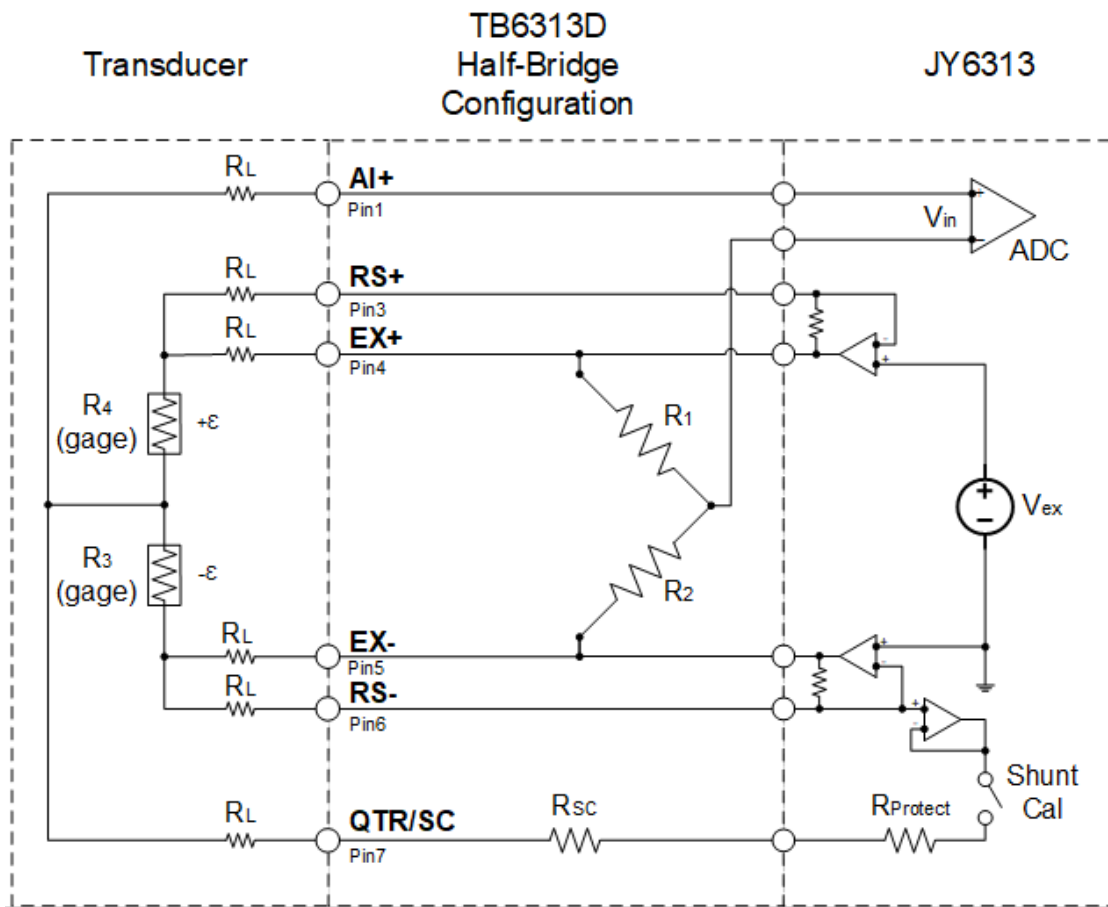

Figure 24 Half-Bridge Type II Circuit Diagram

The following symbols apply to the circuit diagram and equations:

- R_1 and R_2 —Half-bridge completion resistors located inside TB-6313D.
- R_3 —Active element measuring compressive strain ($-\epsilon$).
- R_{SC} —Shunt calibration resistor located inside TB-6313D.
- R_4 —Active element measuring tensile strain ($+\epsilon$).
- R_L —Lead resistance.
- GF —Gage Factor, specified by the gage manufacturer.
- V_{in} —Measured voltage of the bridge.
- V_{ex} —Excitation voltage provided by JY-6313.
- $R_{Protect}$ —10k Ω resistor in series with the Shunt Cal switch to protect against external fault voltages. The total shunt cal resistance is equal to the R_{SC} and $R_{Protect}$ series combination.
- e —ratiometric bridge output defined by the following equation:

$$e = \frac{V_{in}}{V_{ex}}$$

Strain conversion formula:

$$\varepsilon = \frac{-2e}{GF}$$

6.5.5 Full-Bridge Type I

Full-Bridge Type I is configured specifically to measure bending strain. Refer to Figure 25 and Figure 26 for the strain-gauge positioning and circuit wiring. This configuration supports both TB-6313D terminal block and general terminal block.

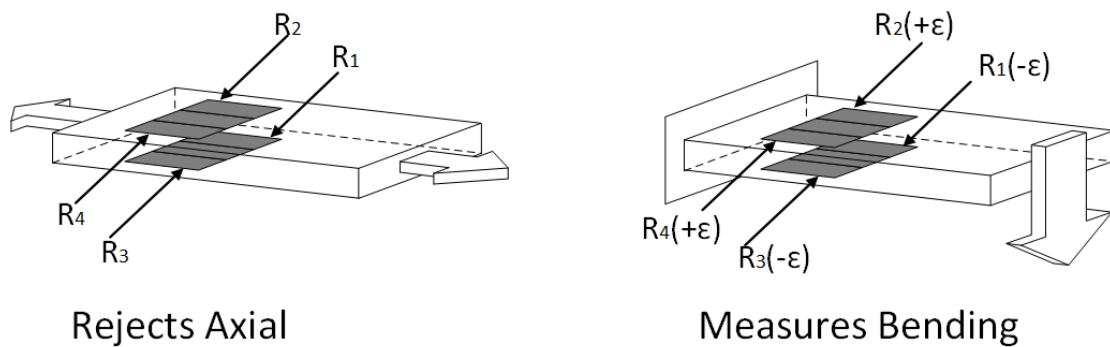

Figure 25 Full-Bridge Type I Rejecting Axial and Measuring Bending Strain

A full-bridge type I configuration has the following characteristics:

- Contains four active strain gauges: two on each side (top and bottom) in the direction of bending strain.
- Highly sensitive to bending strain, rejecting axial strain.
- Sensitivity: $\sim 2\mu\text{V/V}$ per $\mu\text{ε}$, for $GF = 2.0$.

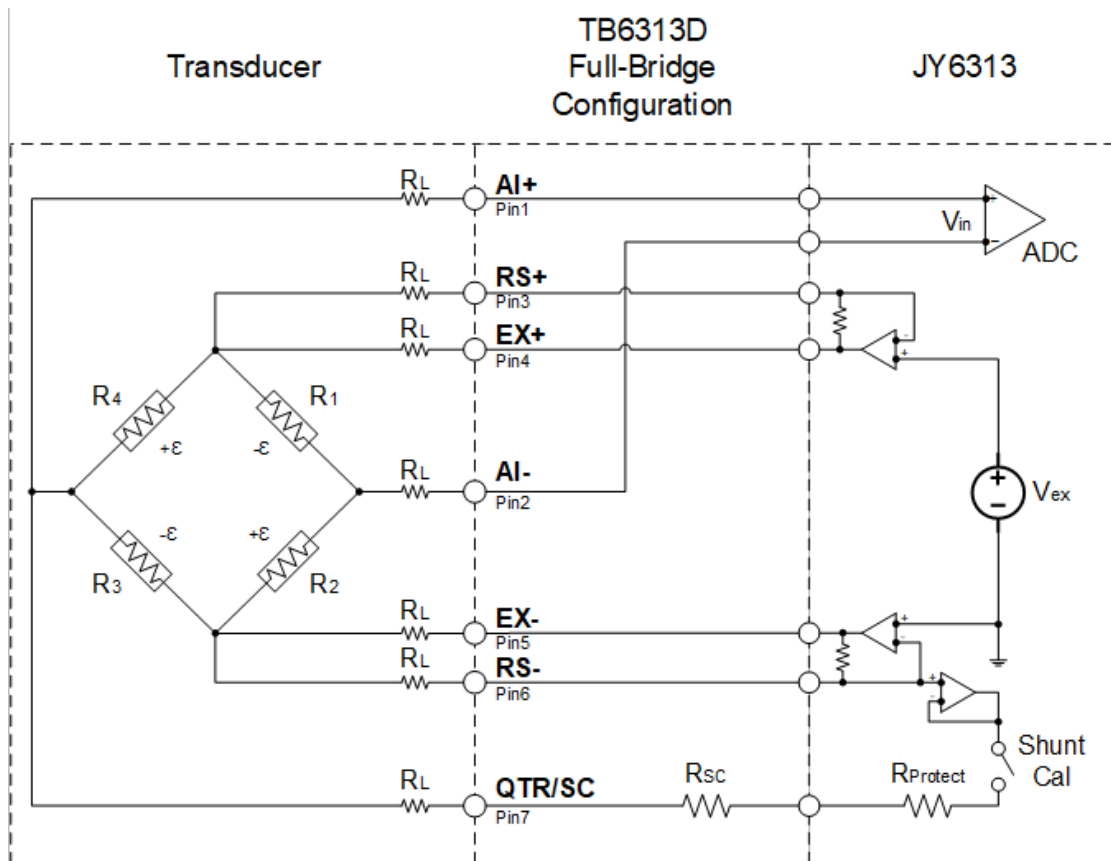

Figure 26 Full-Bridge Type I Circuit Diagram

The following symbols apply to the circuit diagram and equations:

- R_1 —Active element measuring compressive strain ($-\epsilon$).
- R_2 —Active element measuring tensile strain ($+\epsilon$).
- R_3 —Active element measuring compressive strain ($-\epsilon$).
- R_4 —Active element measuring tensile strain ($+\epsilon$).
- R_{SC} — Shunt calibration resistor located inside the TB-6313D.
- R_L —Lead resistance.
- GF —Gage Factor, specified by the gage manufacturer.
- V_{in} —Measured voltage of the bridge.
- V_{ex} —Excitation voltage provided by the JY-6313.
- $R_{Protect}$ —10k Ω resistor in series with the Shunt Cal switch to protect against external fault voltages. The total shunt cal resistance is equal to the R_{SC} and $R_{Protect}$ series combination.

- e —ratiometric bridge output defined by the following equation:

$$e = \frac{V_{in}}{V_{ex}}$$

Strain conversion formula:

$$\varepsilon = \frac{-e}{GF}$$

As shown in the circuit diagram, all signals of the bridge are directly connected to the JY-6313, and the TB-6313D only provides the SC resistor at this time. Therefore, you can choose to use TB-6313D or a general terminal block. When using a general terminal block, the shunt resistor R_{sc} must be provided by the user, as shown in Figure 32.

6.5.6 Full-Bridge Type II

The Full-Bridge Type II configuration is also designed for measuring bending strain, with some variations in gauge placement. See Figure 27 and Figure 28 for the layout. This configuration supports both TB-6313D terminal block and general terminal block.

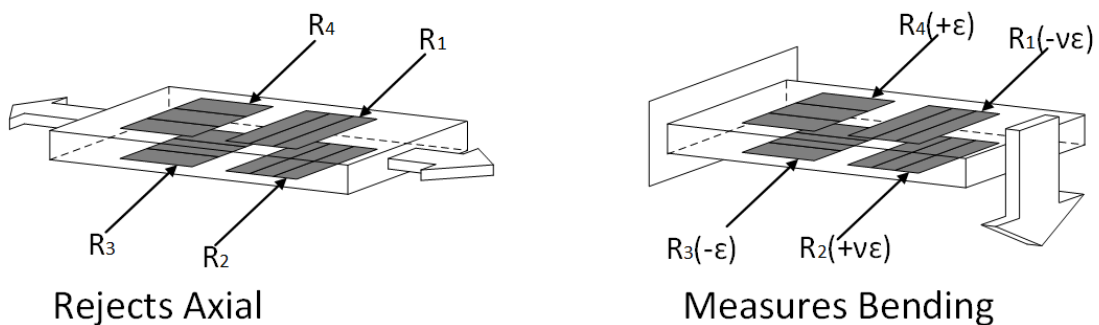

Figure 27 Full-Bridge Type II Rejecting Axial and Measuring Bending Strain

A full-bridge type II configuration has the following characteristics:

- Four active strain gauges: two mounted in the direction of bending strain, and two Poisson gauges perpendicular to the strain axis.
- Rejects axial strain and measures bending strain with high sensitivity.
- Sensitivity $\sim 1.3\mu V/V$ per $\mu\varepsilon$, for $GF = 2.0$.

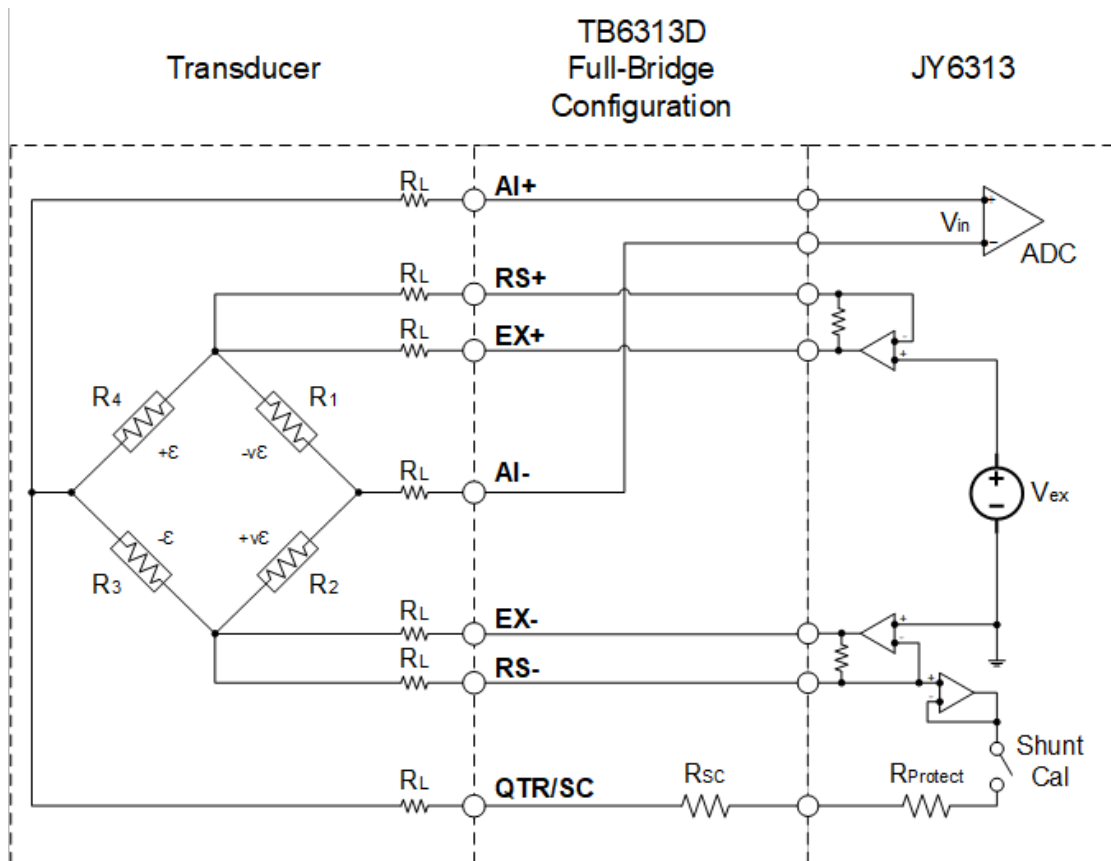

Figure 28 Full-Bridge Type II Circuit Diagram

The following symbols apply to the circuit diagram and equations:

- R_1 —Active element measuring compressive Poisson effect ($-v\epsilon$).
- R_2 —Active element measuring tensile Poisson effect ($+v\epsilon$).
- R_3 —Active element measuring compressive strain ($-\epsilon$).
- R_4 —Active element measuring tensile strain ($+\epsilon$).
- R_{SC} — Shunt calibration resistor located inside the TB-6313D.
- R_L — Lead resistance.
- GF —Gage Factor, specified by the gage manufacturer.
- ν —Poisson’s ratio, defined as the negative ratio of transverse strain to axial strain (longitudinal) strain. Poisson’s ratio is a material property of the specimen you are measuring.
- V_{in} —Measured voltage of the bridge.
- V_{ex} —Excitation voltage provided by JY-6313.

- $R_{Protect}$ —10kΩ resistor in series with the Shunt Cal switch to protect against external fault voltages. The total shunt cal resistance is equal to the R_{SC} and $R_{Protect}$ series combination.
- e —ratiometric bridge output defined by the following equation:

$$e = \frac{V_{in}}{V_{ex}}$$

Strain conversion formula:

$$\varepsilon = \frac{-2e}{GF(1 + \nu)}$$

As shown in the circuit diagram, all signals of the bridge are directly connected to the JY6313, and the TB-6313D only provides the SC resistor at this time. Therefore, you can choose to use TB-6313D or a general terminal block. When using a general terminal block, the shunt resistor R_{SC} must be provided by the user, as shown in Figure 32.

6.5.7 Full-Bridge Type III

Full-Bridge Type III is intended for measuring axial strain and rejecting bending strain. Refer to Figure 29 and Figure 30 for details on strain gauge positioning and wiring. This configuration supports both TB-6313D terminal block and general terminal block.

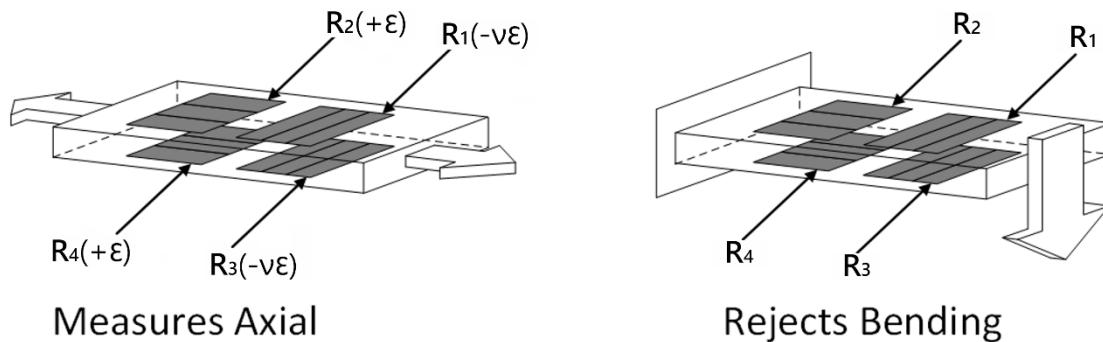

Figure 29 Full-Bridge Type III Measuring Axial and Rejecting Bending Strain

A full-bridge type III configuration has the following characteristics:

- Contains four active strain gauges: two for measuring axial strain and two Poisson gauges transverse to the principal axis.
- Rejects bending strain.
- Sensitivity $\sim 1.3\mu V/V$ per $\mu\varepsilon$, for $GF = 2.0$.

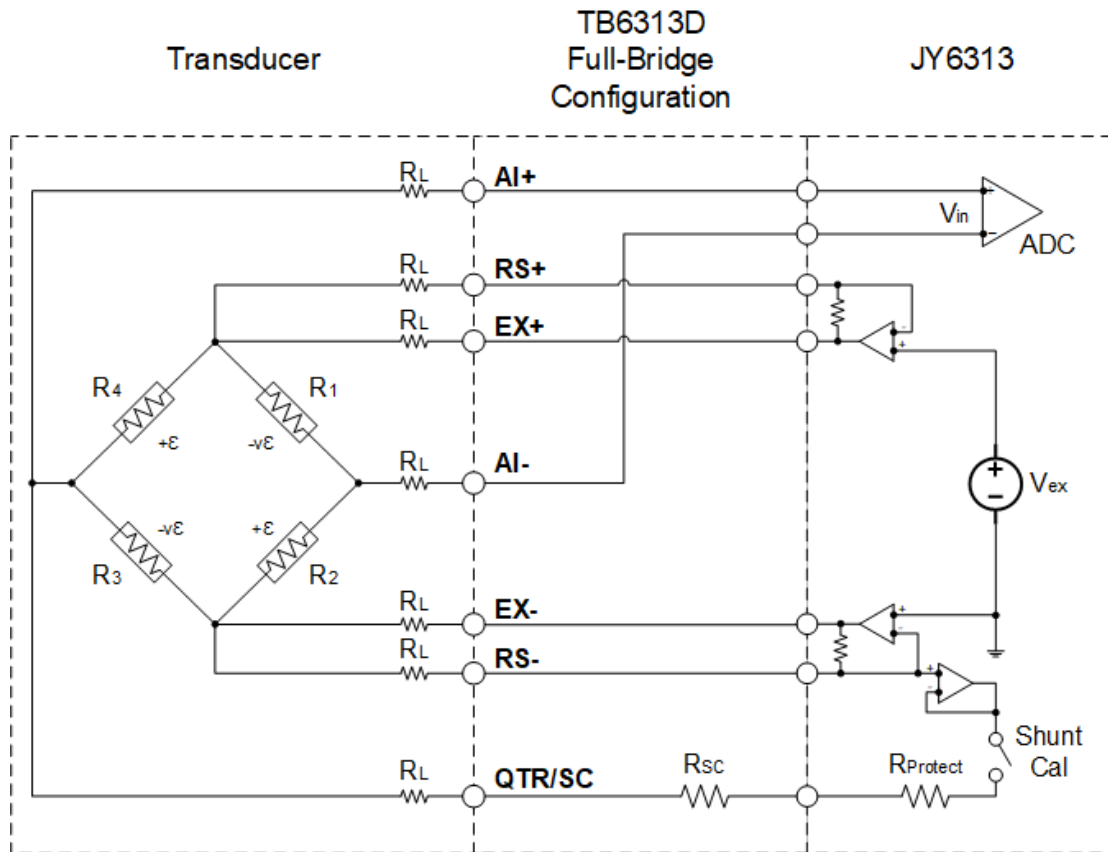

Figure 30 Full-Bridge Type III Circuit Diagram

The following symbols apply to the circuit diagram and equations:

- R_1 —Active element measuring compressive Poisson effect ($-v\epsilon$).
- R_2 —Active element measuring tensile strain ($+\epsilon$).
- R_3 —Active element measuring compressive Poisson effect ($-v\epsilon$).
- R_4 —Active element measuring the tensile strain ($+\epsilon$).
- R_L —Lead resistance.
- GF —Gage Factor, specified by the gage manufacturer.
- ν —Poisson’s ratio, defined as the negative ratio of transverse strain to axial strain (longitudinal) strain. Poisson’s ratio is a material property of the specimen you are measuring.
- R_{SC} —Shunt calibration resistor located inside the TB-6313D.
- V_{in} —Measured voltage of the bridge.
- V_{ex} —Excitation voltage provided by JY-6313.

- $R_{Protect}$ —10kΩ resistor in series with the Shunt Cal switch to protect against external fault voltages. The total shunt cal resistance is equal to the R_{SC} and $R_{Protect}$ series combination.
- e —ratiometric bridge output defined by the following equation:

$$e = \frac{V_{in}}{V_{ex}}$$

Strain conversion formula:

$$\varepsilon = \frac{-2e}{GF[(\nu + 1) - e(\nu - 1)]}$$

As shown in the circuit diagram, all signals of the bridge are directly connected to the JY-6313, and the TB-6313D only provides the SC resistor at this time. Therefore, you can choose to use TB-6313D or a general terminal block. When using a general terminal block, the shunt resistor R_{SC} must be provided by the user, as shown in Figure 32.

6.6 Ratiometric Measurement Configuration

JY-6313 can also be used for general full-bridge ratiometric measurements, in which case the measurement result is a ratiometric value with the unit mV/V. This configuration supports both TB-6313D terminal block and general terminal block.

When using TB-6313D for wiring, the schematic diagram is shown in Figure 31.

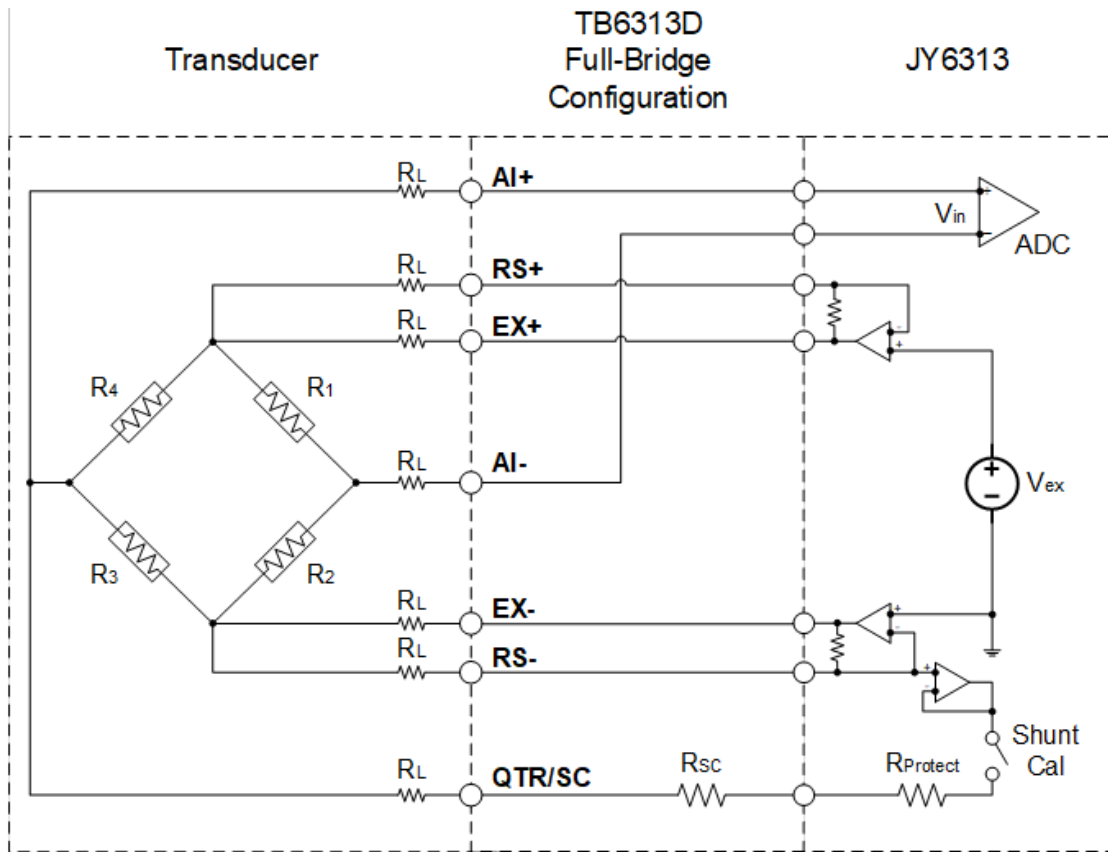

Figure 31 Full-Bridge with TB-6313D Circuit Diagram

When using a general terminal block, the schematic diagram is shown in Figure 32.

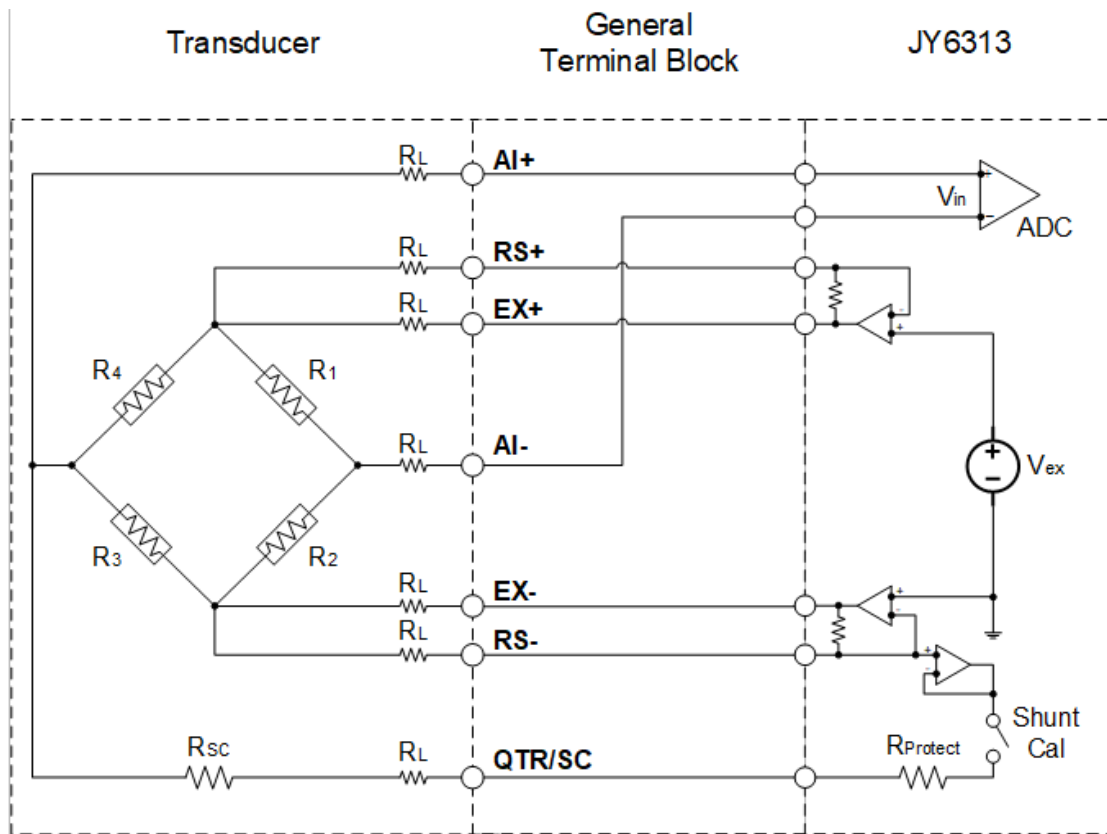

Figure 32 Full-Bridge with General Terminal Block Circuit Diagram

To add a ratiometric measurement channel, do as shown in the code below:

```
//Add Ch0 for ratiometric measurement
//Vex=5.0V, RangeLow=-80mV/V, RangeHigh=80mV/V
_aiTask.AddChannel(0, 5.0, -80, 80);
```

7. Operating JY-6313

7.1 Quick Start

After you have installed the driver software and the SeeSharpTools, you are ready to use Microsoft Visual Studio C# to operate the JY-6313 products. This chapter will take JY-6313 as an example for the introduction. If you are already familiar with Microsoft Visual Studio C#, the quickest way to use JY-6313 boards is to go through our extensive examples. We provide source code of our examples. In many cases, you can modify the source code and start to write your applications. We also provide Learn by Example in the following sections. These examples will help you navigate and learn how to use this JY-6313.

7.2 Acquisition Methods

JY-6313 uses a Δ - Σ modulator and a digital filter to acquire analog signals, which can realize the acquisition of 16 channels of analog signals. You need to configure AI channels and set up some parameters through JY-6313 driver software. The most important parameters are Data Acquisition mode, Sample Rate, SamplesToAcquire, Channel Count, Channel Range, Strain Configuration, Excitation Voltage and Gage Nominal Resistance. For Data Acquisition, JY-6313 provides 3 acquisition modes: Continuous, Finite and Single Point.

SampleRate: How fast data are acquired per second per channel. For example, if the sample rate is 1000Hz, you acquire two channels of data, you will have 2000 points/second.

SamplesToAcquire: This parameter needs to be set only when finite acquisition mode is selected, it is the total number of samples to acquire, please see Section 7.2.2. In some examples, this parameter is used to set the size of the buffer for reading data, and every time the amount of samples available exceeds that size, a data read is performed.

Channel Count: how many channels you want to collect data. You can select the channels required for this acquisition. JY-6313 simultaneously collects data from the channels.

Strain Configuration: The strain configuration determines how the strain gage is connected to JY6313 and how JY6313 converts the ratiometric value to the strain value, as described in Chapter 6

Excitation Voltage: Each channel of JY-6313 can provide an adjustable excitation

voltage in the 1.0V to 10.0V range, used to supply excitation voltage to Wheatstone bridge. However, the set excitation voltage values of the 8 channels on the same Bank (Ch0~Ch7 belong to Bank0, Ch8~Ch15 belong to Bank1) must be equal.

Gage Nominal Resistance: Strain gages supplied by sensor manufacturers have nominal resistance values, the most common being 120Ω, 350Ω, and 1kΩ, and there may be a small resistance change after the strain gage is installed. JY6313 requires the resistance parameter of the strain gage in its initial state (as the gage nominal resistance) and uses this parameter to select the appropriate 1/4 bridge completion resistor, or to calculate the simulated variation value when performing shunt calibration.

Learn by example 7.2.

- Connect the two bridges (Ch0 is full-bridge, Ch1 is quarter-bridge) to JY-6313 via TB-6313D.
- Open **Winform AI Continuous Multi-Channel**, Enable Ch0 and Ch1 and set related parameters. This example program will continuously acquire from multiple channels.
- Sample Rate is set by **Sample Rate(Sa/s)**.
- **Samples to Acquire** is the samples to be acquired for each channel in one block. The continuous mode will acquire blocks after blocks until Stop button is pressed.
- The acquisition will begin immediately after clicking the Start button.
- The result is shown below.



Figure 33 Multi-Channel Acquisition Result

7.2.1 Continuous Acquisition

An AI acquisition task will acquire the data continuously until the task is stopped. The JY-6313 device will continue acquiring data and save the data in a FIFO buffer. You specify how many samples to read back by the user buffer's length, if your program does not read the data fast enough, the FIFO buffer may overflow. In this case, the driver software will throw out an error message.

7.2.2 Finite Acquisition

In the Finite Acquisition mode, an AI acquisition task will capture specific total number of samples by the parameter, SamplesToAcquire. You can use the sample program **Winform AI Finite** to learn more about Finite Acquisition.

7.2.3 Single Point

Acquisition In the Single Acquisition mode, it is to capture a single sample for each acquisition. You can use the sample program: **Console AI Single Point** to learn more about single point acquisitions

7.3 Operation Modes

JY6313's digital down sampling filter has two modes: Normal and Low-Latency. The driver automatically selects the mode based on the values of the OperationMode property and the sampling rate property. Details of the different OperationMode options are as follows.

7.3.1 Normal Mode

Normal Mode has $0.4535f_s$ passband bandwidth, high latency (filter group delay), and supported sample rate ranges from 500S/s to 80kS/s.

In this mode, the group delays at different sample rates are shown in Table 33, and the frequency respond is shown in Figure 34.

Sample Rate	Group Delay (Samples)
$500S/s \leq f_s \leq 32kS/s$	33.38
$32kS/s < f_s \leq 64kS/s$	41.25
$64kS/s < f_s \leq 80kS/s$	48.00

Table 33 Digital Filter Group Delay (Operation Mode = Normal)

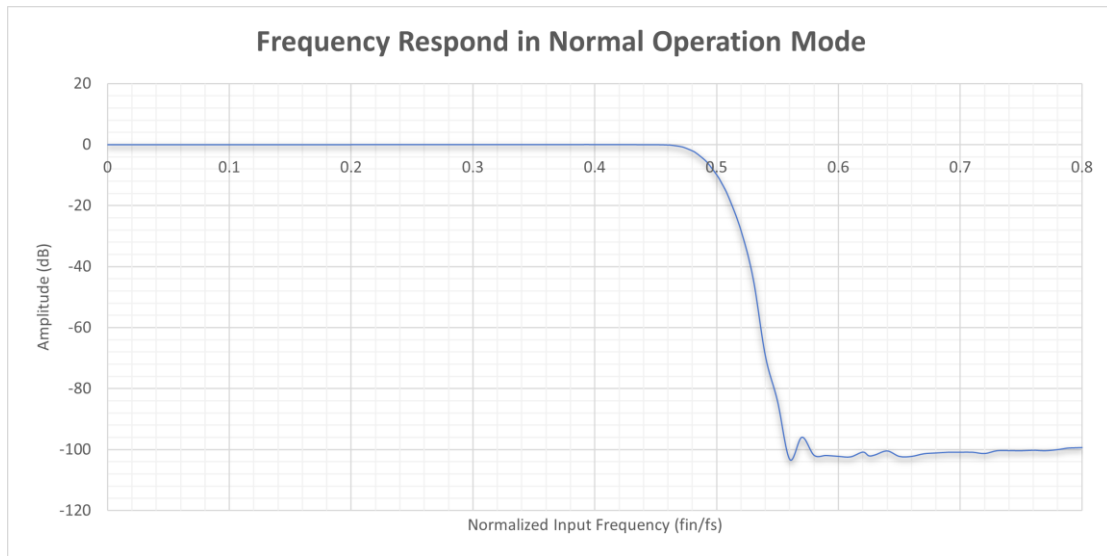

Figure 34 Frequency Response (OperationMode=Normal)

7.3.2 Low-Latency Mode

Low-Latency mode has $0.1f_s$ passband bandwidth, low latency (filter group delay), and supported sample rate ranges from 7.8125S/s to 4kS/s.

In this mode, the group delays at different sample rates are shown in Table 34, and the frequency response is shown in Figure 35.

Sample Rate	Group Delay (Samples)
$7.8125S/s \leq f_s \leq 62.5S/s$	0.82
$62.5S/s < f_s \leq 4kS/s$	0.88

Table 34 Digital Filter Group Delay (Operation Mode = LowLatency)

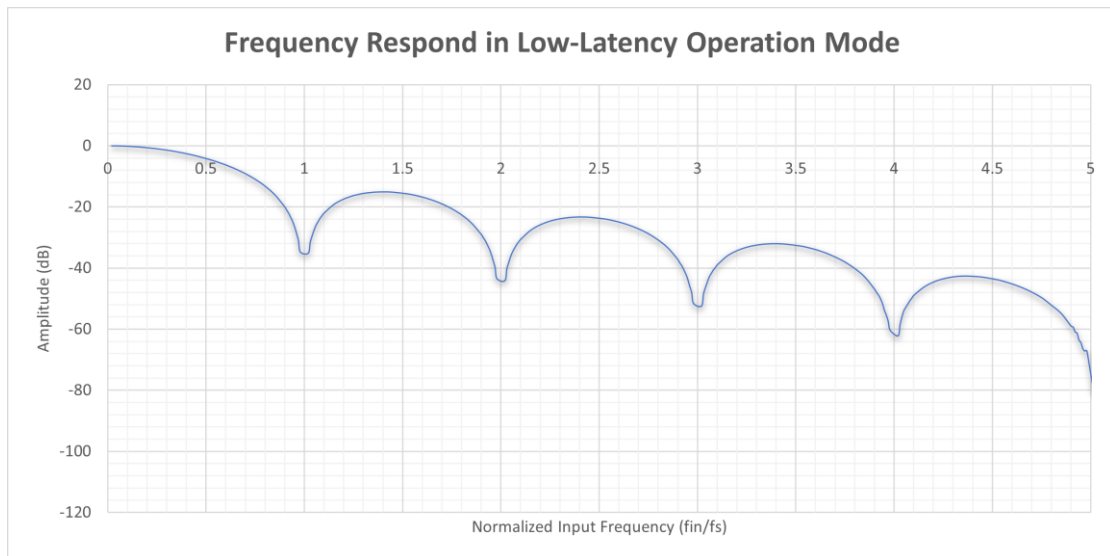

Figure 35 Frequency Respond (OperationMode = LowLatency)

7.3.3 Auto Mode

Automatic mode is the default mode. The driver will use Normal mode if sample rate is greater than or equal to 500S/s, otherwise, use Low-Latency mode. The group delays at different sample rates are shown in Table 13.

7.4 Strain Measurement Range

The JY-6313 offers a total of 5 input gain options: x6.25, x12.5, x25, x50, and x100. The measurable microstrain range under each gain option is also related to several factors, including:

- **Strain Gage Configuration:** The setup and arrangement of the strain gages affect the sensitivity and the range of measurement. Different configurations can provide different sensitivities and thus different measurable ranges.
- **Excitation Voltage:** The voltage provided to the bridge can influence the strength of the output signal, which in turn affects the measurable range. Higher excitation voltage can increase the signal-to-noise ratio but reduce the maximum measurable strain.
- **Strain Gage Factor:** The GF of the strain gages often represents its sensitivity.

- **Material Poisson's Ratio:** If the measurement involves the calculation of lateral strain or if the material's transverse strain affects the measurement, the Poisson's ratio of the material is relevant. This ratio describes the material's tendency to expand or contract in the direction perpendicular to the applied force.

For reference, the microstrain measurement range of JY-6313 under specific conditions* for various strain gage configurations and gain is shown in Table 35.

*These conditions are:

- Excitation Voltage = 5.0V
- GF = 2.0
- Poisson's Ratio = 0.5

Microstrain($\mu\epsilon$) range(low/high) in different configurations					
Strain Gage Configuration	Gain=x6.25	Gain=x12.5	Gain=x25	Gain=x50	Gain=x100
Quad-Bridge Type I	-137931	-74074	-38472	-19608	-9901
	+190476	+86957	+41667	+20408	+10101
Quad-Bridge Type II	-137931	-74074	-38472	-19608	-9901
	+190476	+86957	+41667	+20408	+10101
Half-Bridge Type I	-101266	-51948	-26317	-13245	-6645
	+112676	+54795	+27027	+13423	+6689
Half-Bridge Type II	-80000	-40000	-20000	-10000	-5000
	+80000	+40000	+20000	+10000	+5000
Full-Bridge Type I	-40000	-20000	-10000	-5000	-2500
	+40000	+20000	+10000	+5000	+2500
Full-Bridge Type II	-53333	-26667	-13333	-6667	-3333
	+53333	+26667	+13333	+6667	+3333
Full-Bridge Type III	-51948	-26317	-13245	-6645	-3328
	+54795	+27027	+13423	+6689	+3339
<i>Condition: Vex=5.0V, GF=2.0, $\nu=0.5$</i>					

Table 35 Microstrain range in different configurations

When you add a channel to JY6313AITask, you only need to set the upper and lower limits of the microstrain ($\mu\epsilon$) to be measured, and the driver will automatically match the appropriate gain.

7.5 Bridge Calibration

As mentioned in Chapter 6.2, JY6313 provides offset nulling and shunt calibration functions for on-site bridge calibration after the measurement system has been set up. To ensure these

bridge calibration functions work correctly, you need to follow these steps as shown in Figure 36 to operate JY-6313:

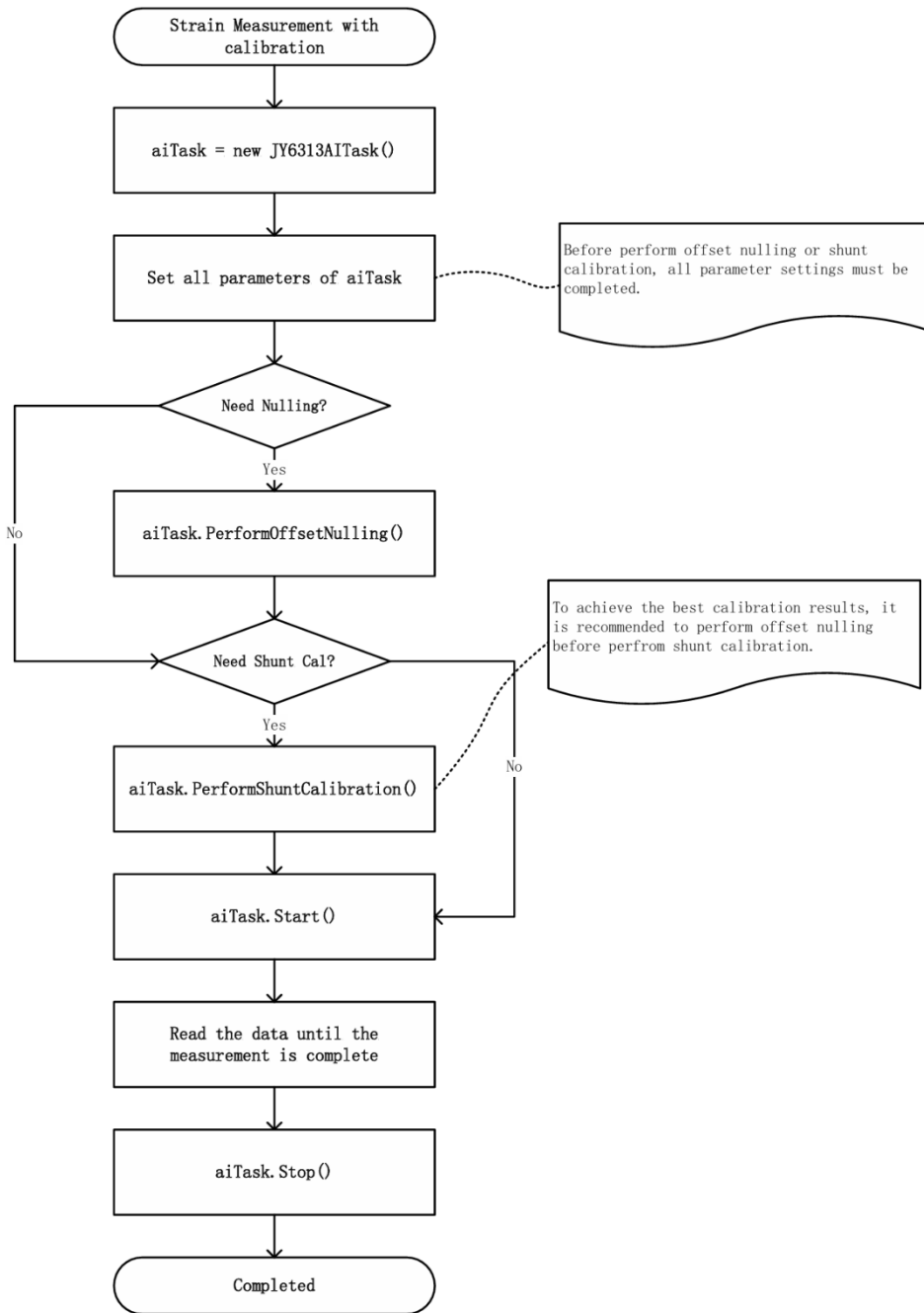

Figure 36 Bridge calibration process

7.5.1 Perform Offset Nulling

During the offset nulling process, JY-6313 will repeatedly measure the input voltage and adjust the output voltage of the internal offset voltage generator until the voltage input to the ADC is as close to 0V as possible, or until the output of the bias voltage generator reaches its maximum range. The typical time required for this process is about 300ms, but it is also related to the number of channels that enabled, the initial input value, and the sample rate. Before the completion of offset nulling, it is essential to ensure that the external input is in a stable state.

7.5.2 Perform Shunt Calibration

In the process of shunt calibration, similar to the offset nulling process, JY-6313 measures the input voltage once when the SC switch is open and once when it is closed. JY-6313 compares the two measurement results to calculate a gain adjustment coefficient. Before the completion of the shunt calibration, it is essential to ensure that the external input is in a stable state.

7.5.3 Use Offset Nulling and Shunt Calibration Manually

In most cases, use `JY6313AITask.OffsetNulling()` and `JY6313AITask.PerformShuntCalibration()` before starting the task allows you to begin measuring strain from a state where the initial offset and gain errors have already been removed. In certain special cases, such as long-term strain monitoring applications, you may also record the calibration coefficient after the first bridge calibration and continue to use these coefficients in subsequent measurements. To get the coefficient that automatically updated by `JY6313AITask.OffsetNulling()` and `JY6313AITask.PerformShuntCalibration()`, do as shown in the code below:

```
//Perform offset nulling on Ch0
_aiTask.PerformOffsetNulling(0);

//Perform shunt calibration on Ch0
_aiTask.PerformShuntCalibration(0);

//Get the bridge calibration coefficients updated by JY6313 through following properties:
double coarseOffset = _aiTask.Channels[0].NullingCoef[0];
double fineOffset = _aiTask.Channels[0].NullingCoef[1];
double gainAdjustment = _aiTask.Channels[0].GainAdjustment;
//Record these coefficients in your program and use them directly next time

_aiTask.Start();
```

To use the recorded coefficients, do as shown in the code below:

```
//Set bridge calibration coefficients through following properties:
```

```
_aiTask.Channels[0].NullingCoef[0] = coarseOffset;
```

```
_aiTask.Channels[0].NullingCoef[1] = fineOffset;
```

```
_aiTask.Channels[0].GainAdjustment = gainAdjustment;
```

```
//Start task, JY6313 will apply the bridge calibration coefficients that have been written
```

```
_aiTask.Start();
```

7.6 Trigger Source

JY-6313 has 4 trigger types: Immediate trigger, Software trigger, Analog trigger, and Digital trigger. The trigger type is a property and set by driver software. Users can employ different triggering types to meet the measurement requirements under different working conditions

7.6.1 Immediate trigger

This trigger mode does not require configuration and is triggered immediately when an operation starts.

Learn by example 7.6.1

Use the same program and connection as in **Learn by Example 7.2**.

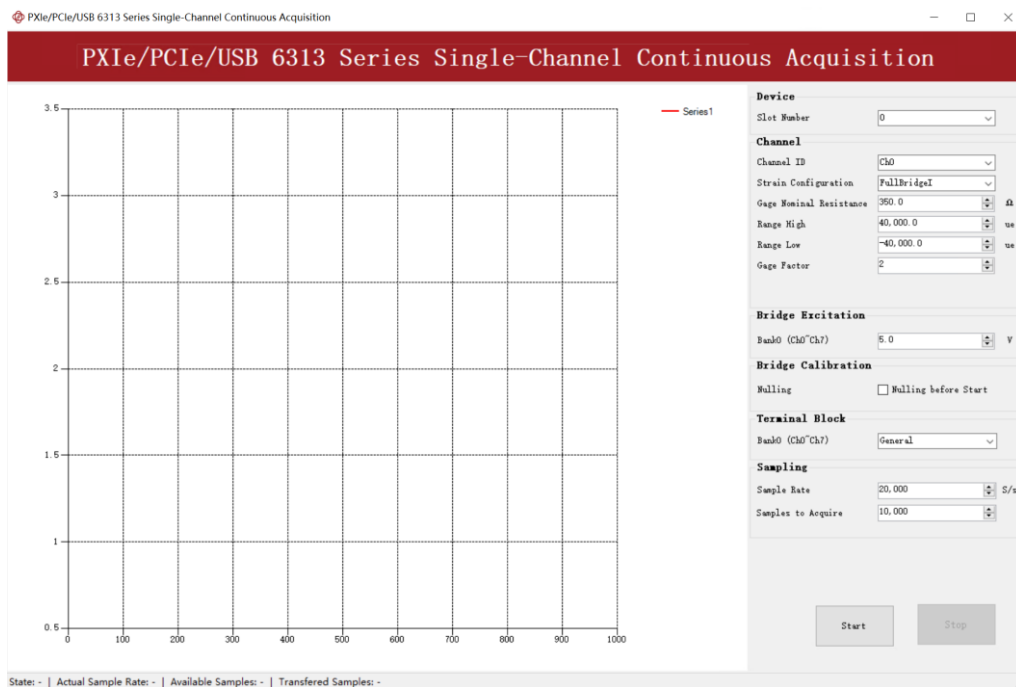

Figure 37 Parameter of Immediate trigger

With Immediate trigger you can click **Start** button to generate the task instead of sending a trigger signal.

7.6.2 Soft trigger

A software trigger must be configured by the driver's software. The trigger starts when a trigger software routine is called.

Learn by example 7.6.2

- Connect a full-bridge of strain gages to JY-6313 Ch0 via TB-6313D.
 - Open **Winform AI Continuous Soft Trigger**, select CH0, use default range set and keep other parameters as default.
 - Click Start to run the task.
- Data will not be acquired until there is a positive signal from Software Trigger when Send Soft Trigger is clicked.
- After sending the trigger signal, the result will be shown in figure below:

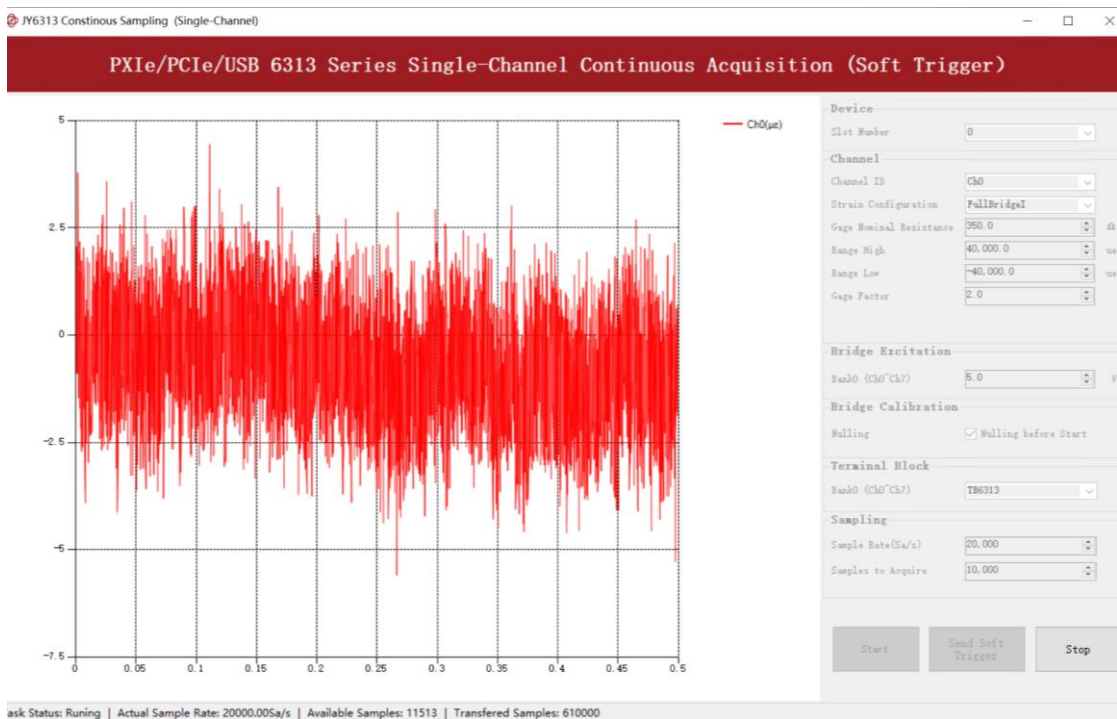

Figure 38 Acquisition result of soft trigger

7.6.3 External Analog Trigger

You can assign one of measurement channels as the analog trigger source. JY6313 provides three analog trigger modes

- Edge comparator,
- Hysteresis comparator,
- Window comparator.

Analog trigger threshold range can be arbitrarily selected in the effective range of the selected channel. When setting the threshold, please pay attention to the physical unit currently in use.

Edge comparator

In the Edge comparator, there are two trigger conditions: *Rising Slope Trigger* and *Falling Slope Trigger*.

Rising Slope Trigger: The Edge comparator output is high when the signal goes above the threshold; the output is low when the signal goes below the threshold as shown in Figure 39.

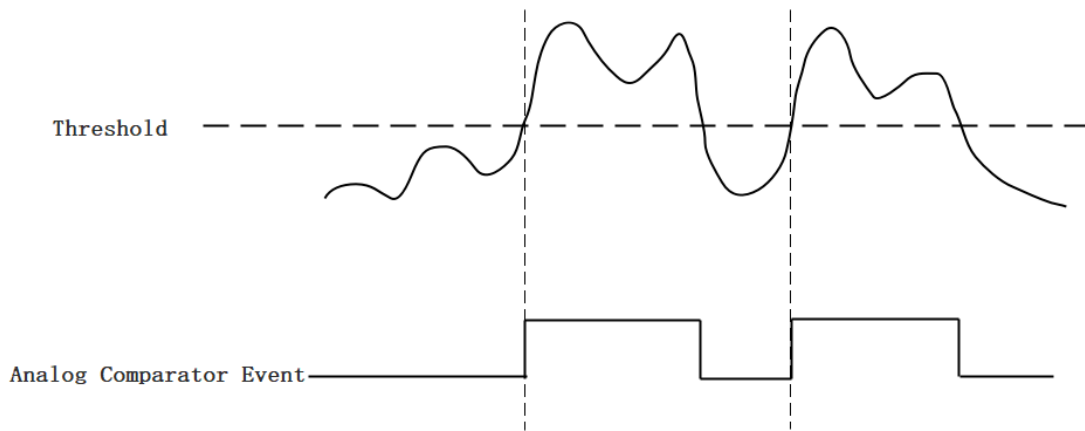

Figure 39 Rising Slope Trigger

Falling Slope Trigger: The Edge comparator output is high when the signal goes below the threshold; the output is low when the signal goes above the threshold as shown in Figure 40.

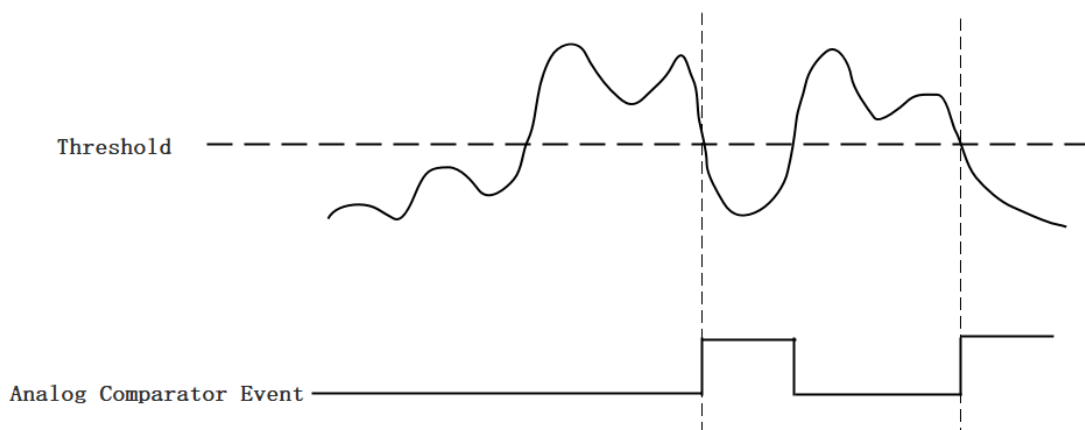

Figure 40 Falling Slope Trigger

Hysteresis Comparator

The hysteresis comparator is designed for preventing spurious triggering. You can set hysteresis region by setting high threshold and low threshold. There are two trigger conditions: *Hysteresis with Rising Slope Trigger* and *Hysteresis with Falling Slope Trigger*.

Hysteresis with Rising Slope Trigger: The Hysteresis comparator output is high when the signal must first be below the low threshold, then goes above the high threshold. The output will change to low when the signal goes below the low threshold as shown in Figure 41.

Hysteresis with Falling Slope Trigger: The Hysteresis comparator output is high when the signal must first be above the high threshold, then goes below the low threshold. The output will change to low when the signal goes above the high threshold as shown in Figure 42.

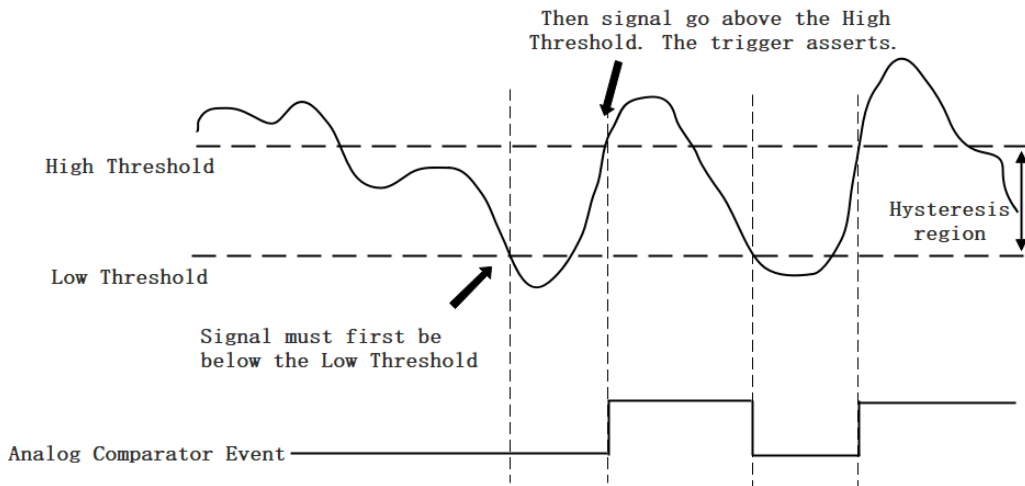

Figure 41 Hysteresis with Rising Slope Trigger

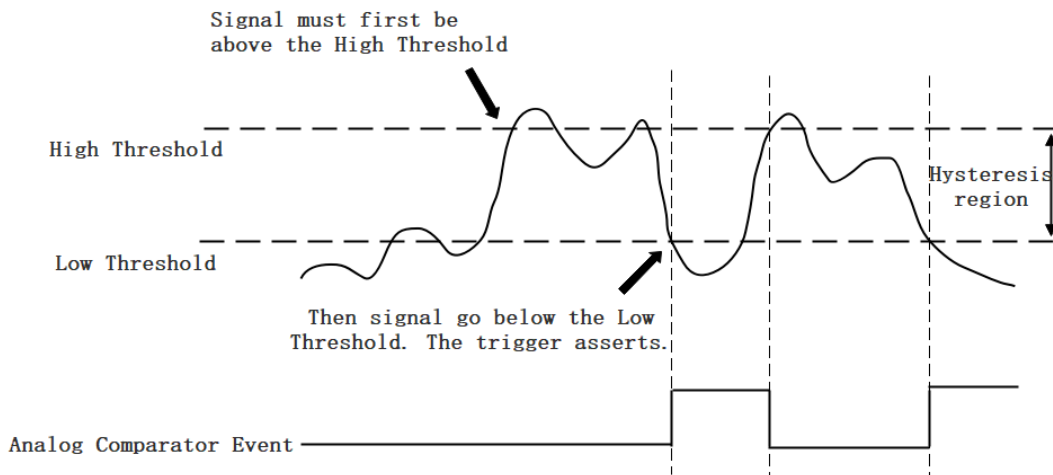

Figure 42 Hysteresis with Falling Slope Trigger

Window comparator

The window comparator is designed to acquire signal from interesting window by setting High Threshold and Low Threshold. There are two trigger conditions: *Entering Window Trigger* and *Leaving Window Trigger*.

Entering Window Trigger: The window comparator output is high when the signal enters the window defined by the *Low Threshold* and *High Threshold*. The output will change to low when the signal leaves the window as shown in Figure 43.

Leaving Window Trigger: The window comparator output is high when the signal leaves the window defined by the *Low Threshold* and *High Threshold*. The output will change to low when the signal enters the window as shown in Figure 44.

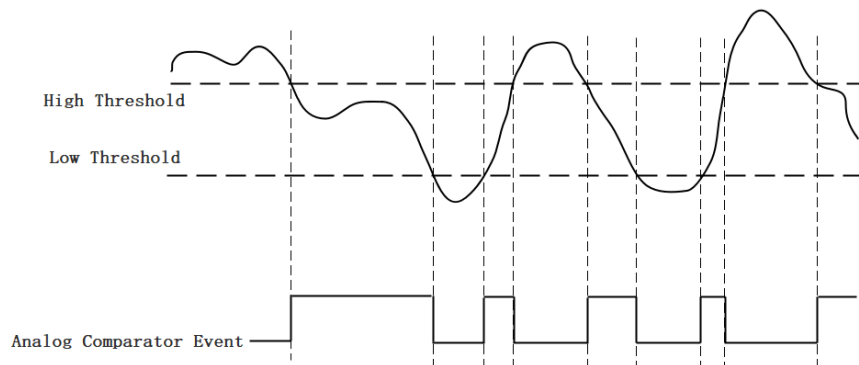

Figure 43 Entering Window Trigger

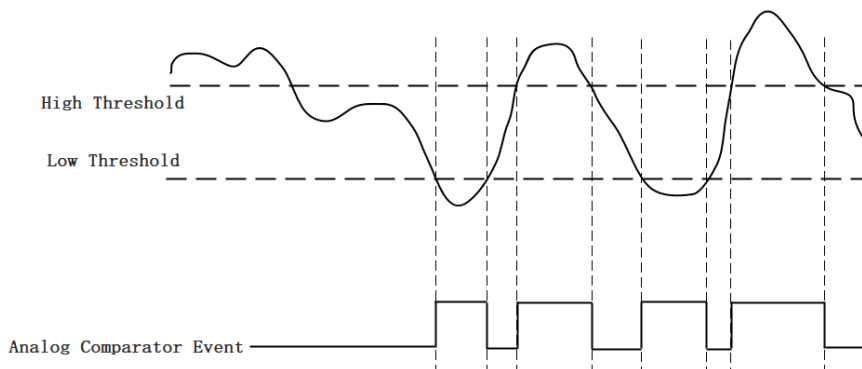

Figure 44 Leaving Window Trigger

Learn by example 7.6.3

- Connect a full-bridge of strain gages to JY-6313 Ch0.
- Open **Winform AI Finite Analog Trigger**, set the following numbers as shown.

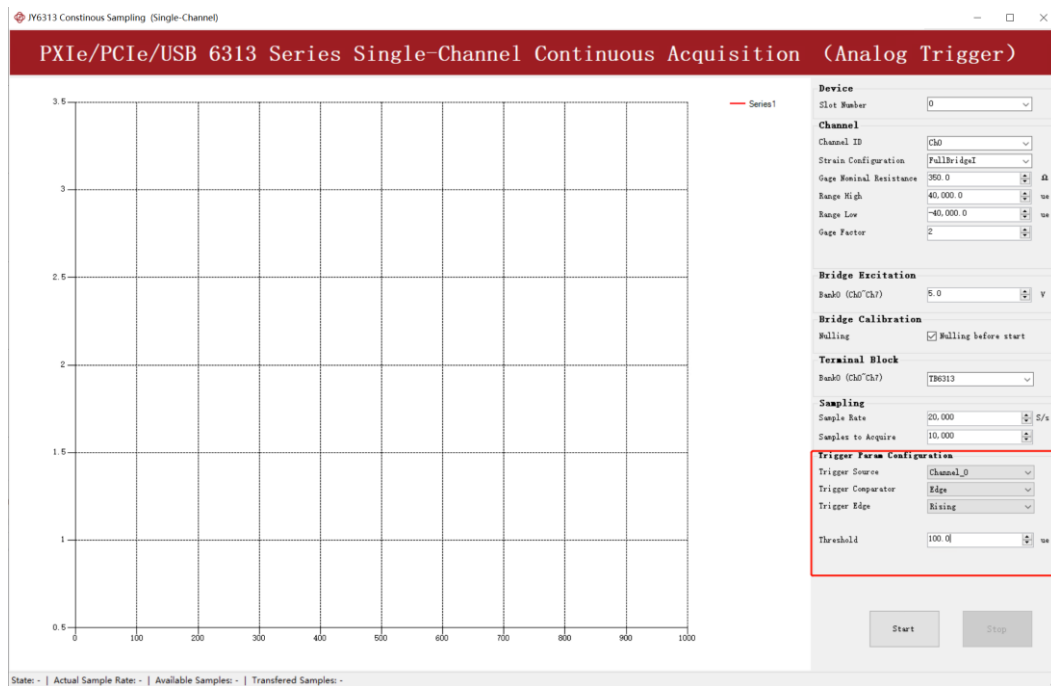

Figure 45 Parameter of External Analog Trigger

- Modes of the *Analog Trigger* are set by **Anlg Trg Comparator**. Set it to **Edge**.
- The edge of *EdgeComparator* set by **Anlg Trg Edge**. (**Rising** and **Falling**). Set it to **Rising**.
- **Trigger source** can be any channel of JY-6313 analog input. Set it to **Channel_0**.
- According to the rules of Rising mentioned above, the signal acquisition will not start until it raises to $100\mu\epsilon$, which is set by **Threshold** above.
- Click Start to run the task.
- This indicates the data acquisition will start only after a triggering event. In this example a trigger signal will occur when the hysteresis comparator meets the condition.
- The result is shown below:

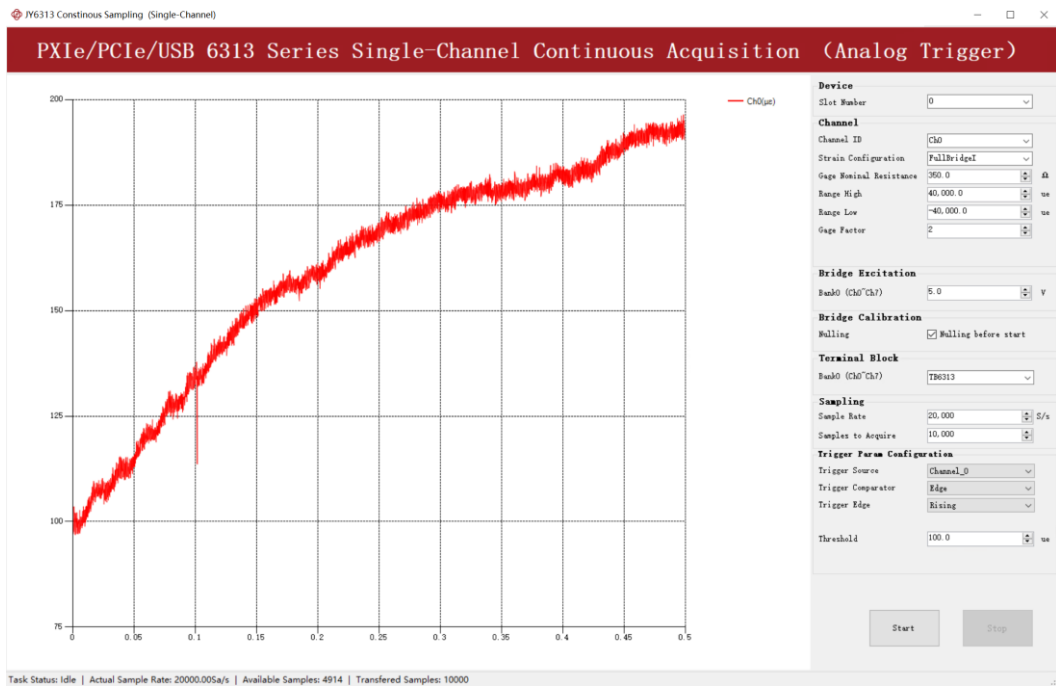

Figure 46 Acquisition result of Analog Trigger

7.6.4 External Digital Trigger

JY-6313 supports different external digital trigger sources from PXI Trigger bus (PXI_TRIG<0..7>), and connectors of front panel (Ext_Trig). The high pulse width of digital trigger signal must be longer than 20 ns for effective trigger. The module will monitor the signal on digital trigger source and wait for the rising edge or falling edge of digital signal which depending on the set trigger condition, then cause the module to acquire the data as shown in Figure 47.

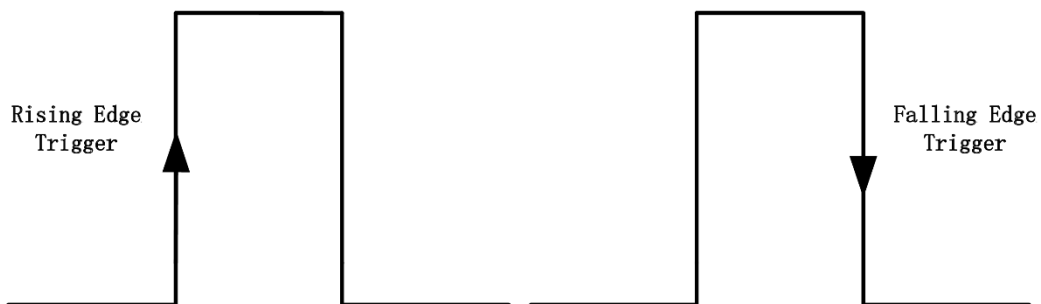

Figure 47 External Digital Trigger

Learn by Example 7.6.4

- Connect a bridge to JY-6313 Ch0 via TB-6313D, and a pulse generator to Ext_Trig through SMB cables.
- Set square wave signal (f=1k, Vpp =5V, Duty = 5%) for Ext_Trig.
- Open **Winform AI Finite Digital Trigger**, set the following numbers as shown below.

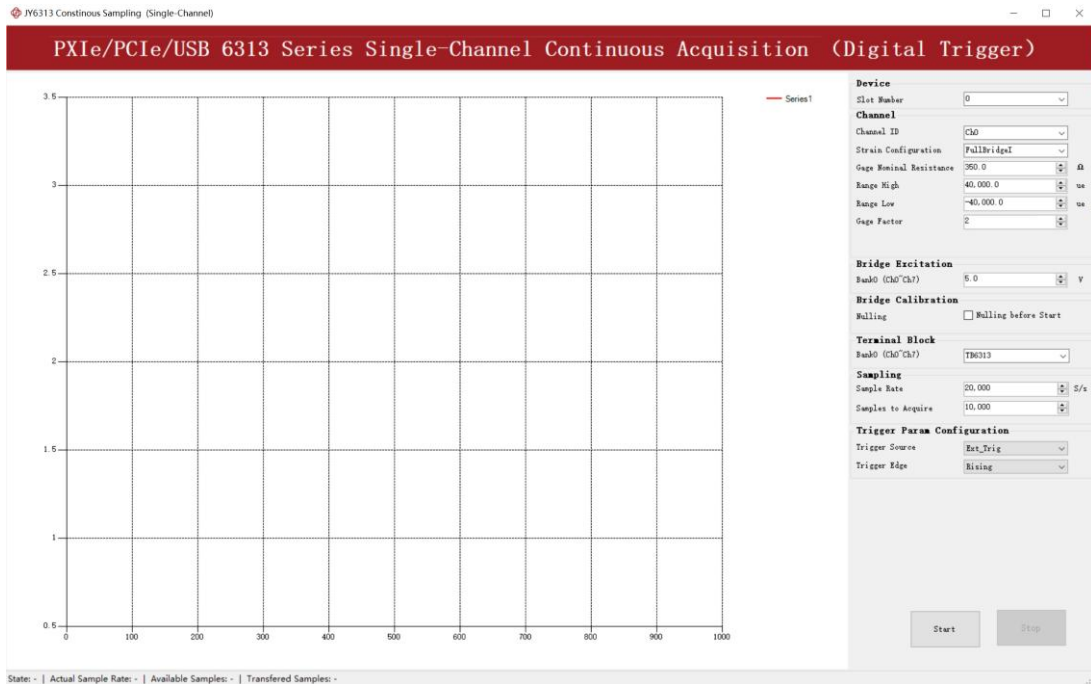

Figure 48 Parameter of Digital Trigger

- *Trigger Source* is set by **Trigger Source**, set it to **Ext_Trig**.
- There are two **Trigger Edge**: **Rising** and **Falling**, set it to **Rising**.
- Click **Start**. Since the square wave is used for the digital trigger source, when a rising edge of the square wave occurs, the digital trigger will be activated, and the data acquisition will start.

7.7 Trigger Mode

The JY-6313's analog inputs support several trigger modes: start trigger, reference trigger, and re-trigger.

7.7.1 Start Trigger

In this mode, data acquisition begins immediately after the trigger. This trigger mode is suitable for continuous acquisition and finite acquisition. As shown in Figure 49.

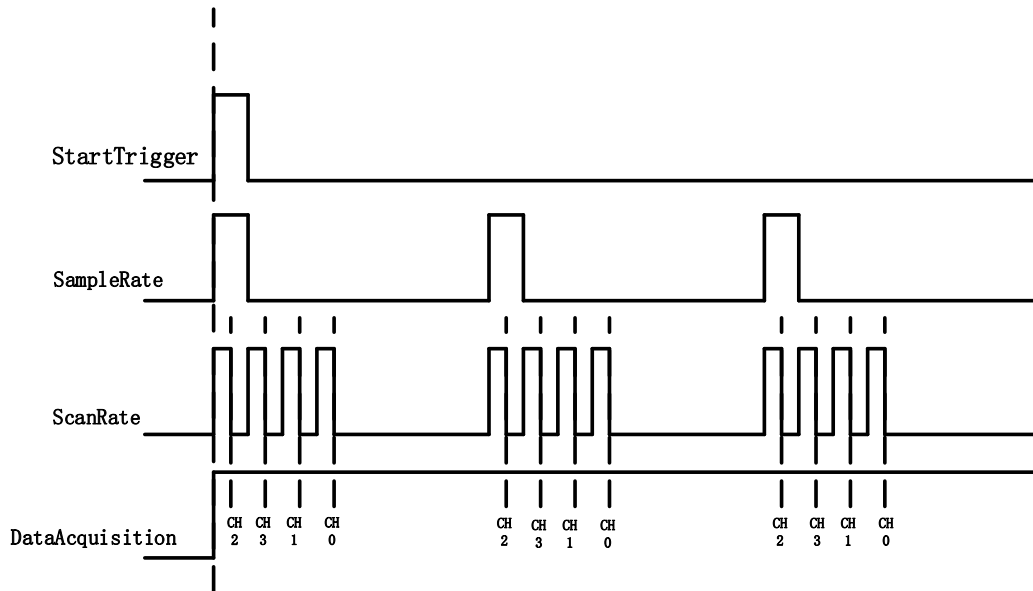

Figure 49 Start Trigger

7.7.2 Reference Trigger

This trigger mode is suitable for finite acquisition. In this mode, user can set the number of pre-trigger samples. The default number of pre-trigger points is 0. First you need to start data acquisition. When the reference trigger condition is met, the routine will return the acquired data points. If the points are less than the pre-trigger samples, the trigger signal be ignored. An example is shown below.

Example

- Total samples: 1000.
- Channel Count: 1
- Pre-trigger samples: 10.
- After triggering, it returns a total of 1000 samples, 10 being pre-triggered, 990 after triggering

The principle is shown in Figure 50.

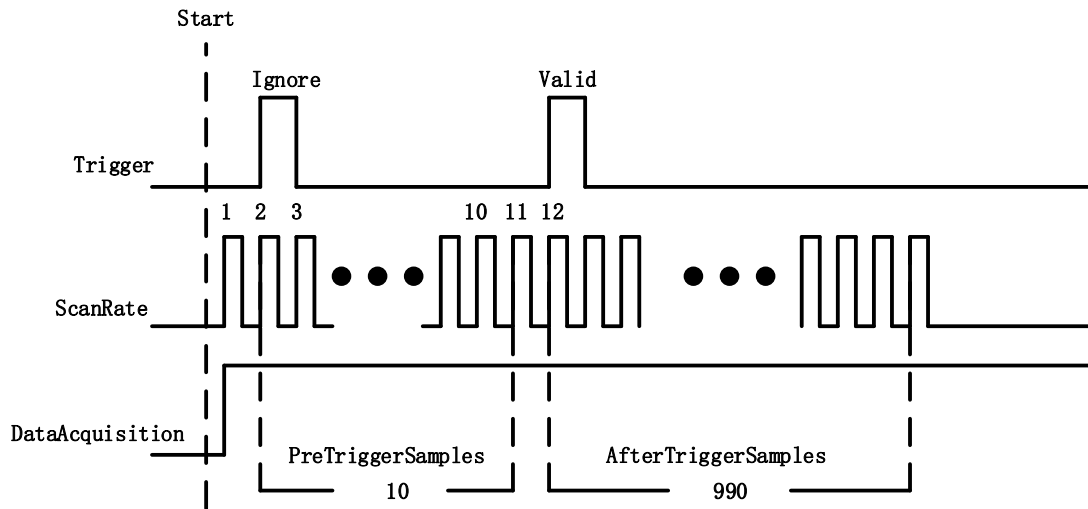

Figure 50 Reference Trigger

7.7.3 Retrigger

JY-6313 series products support retrigger mode. In the retrigger mode, you can set the number of retrigger and the length of each acquisition. Assuming that the number of re triggers is n and the length of each trigger acquisition is m , the length of all acquisition data is $n * m * \text{channel count}$. Show in Figure 51.

When the retrigger count parameter is set to -1, it represents infinite retriggering.

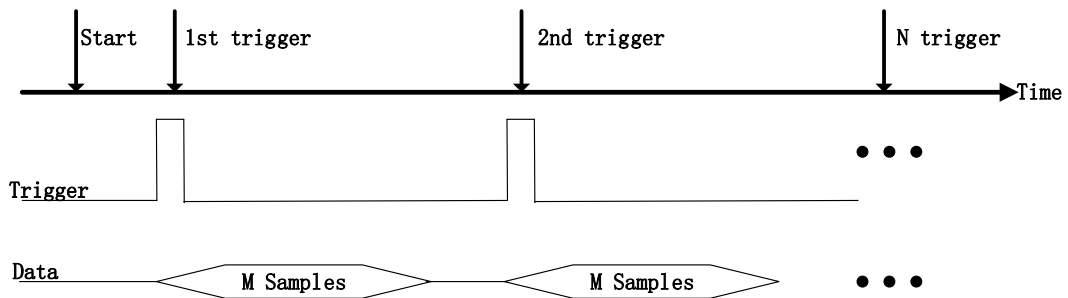

Figure 51 Retrigger

7.8 Sync

The channels on a single JY-6313 always perform synchronized acquisition. When you want to synchronize two or more devices, these devices will be differentiated into a master device and one or more slave devices. To synchronize the acquisition of all devices, you mainly need to complete the following three steps:

1. All devices select the same external reference clock. In the PXIe system, this reference clock is PXIe_CLK100.
2. A sync pulse signal sent by the master device to all slave devices, which will ensure that all ADCs have a sampling rhythm with the same frequency and phase.
3. A trigger signal sent by the master device to all slave devices ensures that all tasks begin the data acquisition at the same moment.

The diagram is shown in Figure 52.

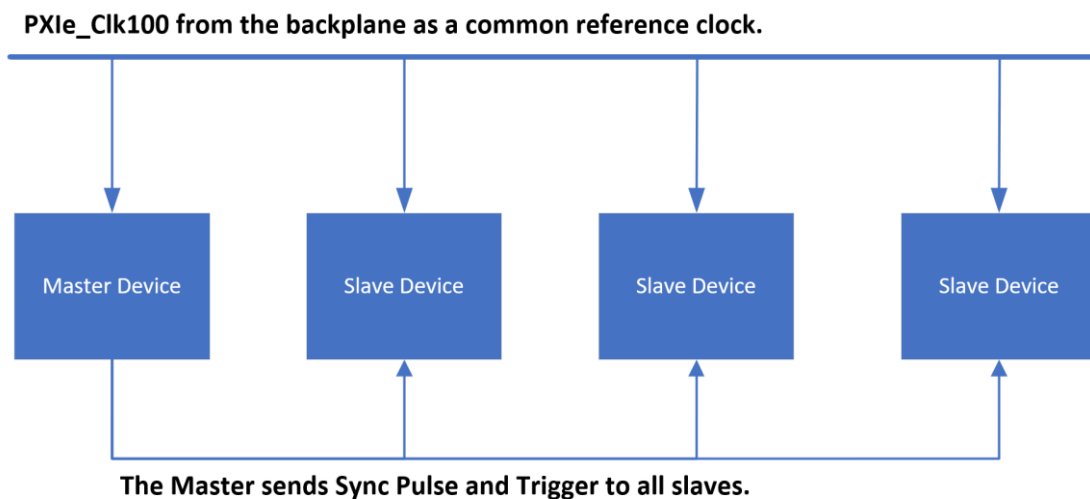

Figure 52 Multi-device Sync Topology

Learn by Example 7.8

- Connect the same signal source to JY-6313(PXIe chassis Slot 0) Ch0 and JY-6313(PXIe chassis Slot1) Ch0 using cables of same length.
- To verify the synchronization accuracy, a signal source generated a 700mVpp, 1kHz sine wave signal (with a common-mode voltage of 1.5V) to simulate the bridge output.
- Open **Winform AI Multi-Device Sync**, set the following parameters as shown in Figure 53.

Figure 53 Parameters of multi-device sync

- Slot Number is the number marked on the top of the PXIe chassis. As shown in Figure 54. Here we set Slot 0 as the Master device, Slot 1 as the Slave device.

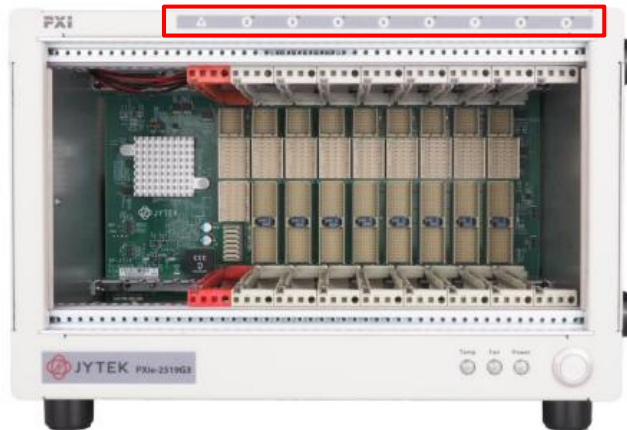

Figure 54 Slot number on PXIe Chassis

- *Reference Clock* set to **PXIe_Clk100**
- *Sync Trigger routing* set to **PXI_Trig0** or other trigger sources that are not in use.
- After clicking the **Commit** button, the Slave device and the Master device will execute

the `JY6313AITask.Commit()` method in sequence. The driver will automatically complete the reference clock locking and other parameter configurations, then the Master device will send a sync pulse to the Slave device through the selected routing path.

The sequence of `JY6313AITask.Commit()` is crucial, the Slave device must execute first, and the Master device must execute last.

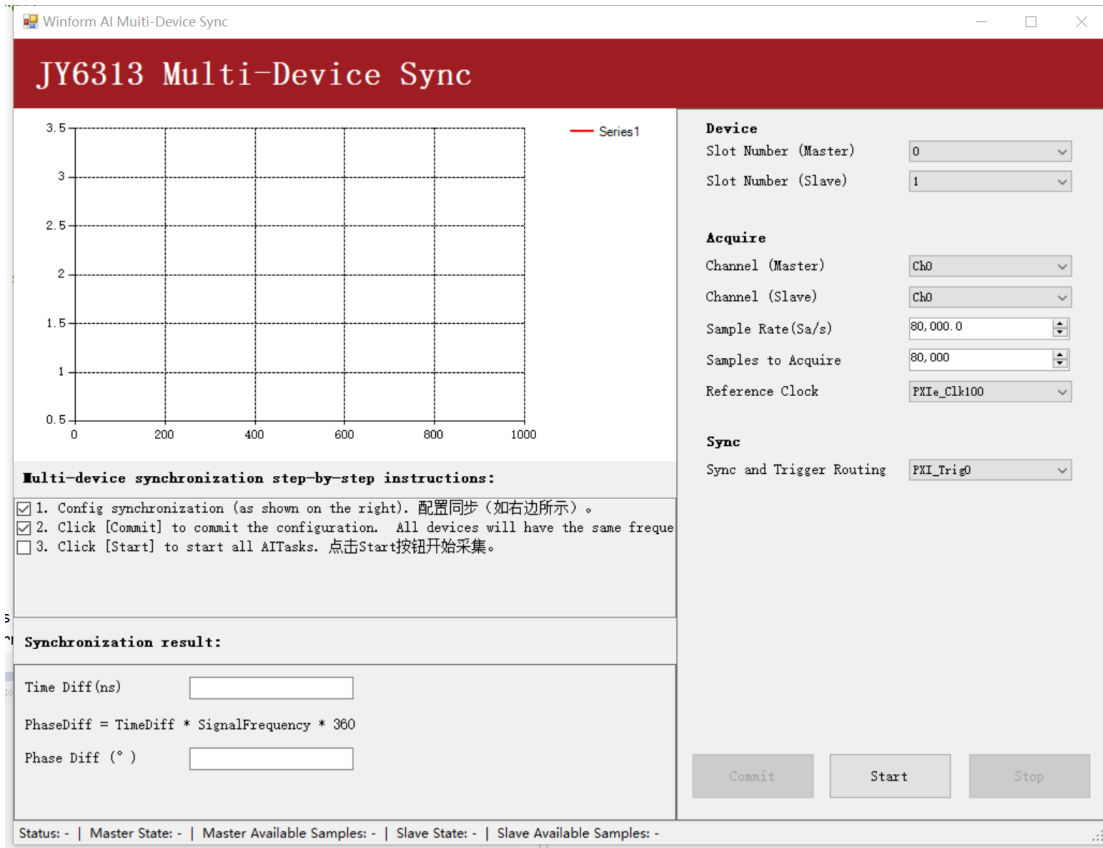

Figure 55 Result after click commit button

After this step is completed, all devices will have sampling clocks with the same frequency and phase, as shown in Figure 56, and the **Start** button is now enabled.



Figure 56 Synchronous sample clock

- Click **Start** button, the Slave device and the Master device will sequentially execute the `JY6313AITask.Start()` method (Once again, this sequence is crucial). The driver will

automatically complete the remaining configuration, and then the Master device will send a trigger signal to the Slave device. Following this, all devices will begin data acquisition at the same moment, as shown in Figure 57.

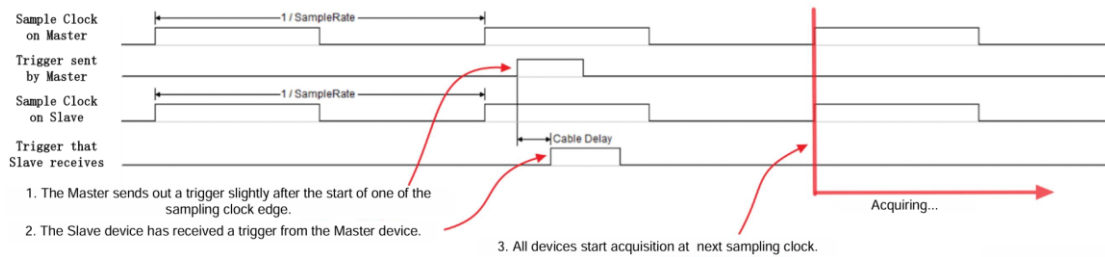

Figure 57 Master sends trigger to slave

The acquisition results (ratiometric value in mV/V) is shown in the figure below.

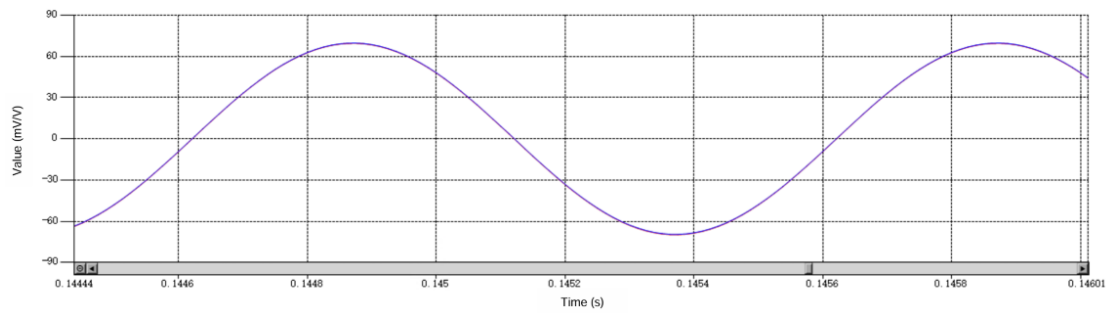

Figure 58 Synchronous acquisition results

8. Calibration

JY-6313 Series boards are pre-calibrated before shipment. We recommend you recalibrate JY-6313 board periodically to ensure the measurement accuracy. A commonly accepted practice is one year. If for any reason, you need to recalibrate your board, please contact JYTEK.

9. Using JY-6313 in Other Software

While JYTEK's default application platform is Visual Studio, the programming language is C#, we recognize there are other platforms that are either becoming very popular or have been widely used in the data acquisition applications. Among them are Python, C++. This chapter explains how you can use JY-6313 DAQ card using one of this software.

9.1 Python

JYTEK provides and supports a native python driver for JY-6313 cards. There are many different versions of Python. JYTEK has only tested in CPython version 3.5. There is no guarantee that JYTEK python drivers will work correctly with other versions of Python.

If you want to be our partner to support different Python platforms, please contact us.

10.About JYTEK

10.1 JYTEK China

Founded in June, 2016, JYTEK China is a leading Chinese test & measurement company, providing complete software and hardware products for the test and measurement industry. The company has evolved from re-branding and reselling PXI(e) and DAQ products to a fully-fledged product company. The company offers complete lines of PXI, DAQ, USB products. More importantly, JYTEK has been promoting open-sourced based ecosystem and offers complete software products. Presently, JYTEK is focused on the Chinese market. Our Shanghai headquarters and production service center have regular stocks to ensure timely supply; we also have R&D centers in Xi'an and Chongqing. We also have highly trained direct technical sales representatives in Shanghai, Beijing, Tianjin, Xi'an, Chengdu, Nanjing, Wuhan, Guangdong, Haerbin, and Changchun. We also have many partners who provide system level support in various cities.

10.2 JYTEK Software Platform

JYTEK has developed a complete software platform, SeeSharp Platform, for the test and measurement applications. We leverage the open sources communities to provide the software tools. Our platform software is also open sourced and is free, thus lowering the cost of tests for our customers. We are the only domestic vendor to offer complete commercial software and hardware tools.

10.3 JYTEK Warranty and Support Services

With our complete software and hardware products, JYTEK is able to provide technical and sales services to wide range of applications and customers. In most cases, our products are backed by a 1-year warranty. For technical consultation, pre-sale and after-sales support, please contact JYTEK of your country.

11.Statement

The hardware and software products described in this manual are provided by JYTEK China, or JYTEK in short.

This manual provides the product review, quick start, some driver interface explanation for JYTEK JY-6313 Series family of multi-function data acquisition boards. The manual is copyrighted by JYTEK.

No warranty is given as to any implied warranties, express or implied, including any purpose or non-infringement of intellectual property rights, unless such disclaimer is legally invalid. JYTEK is not responsible for any incidental or consequential damages related to performance or use of this manual. The information contained in this manual is subject to change without notice.

While we try to keep this manual up to date, there are factors beyond our control that may affect the accuracy of the manual. Please check the latest manual and product information from our website.

Shanghai Jianyi Technology Co., Ltd.

Address: Room 201, Building 3, NO.300 Fangchun Road, Shanghai.

Post Code: 201203

Tel: 021-5047 5899

Website: www.jytek.com